

# Operating Manual

*For*

**DuP/DuPR/DuPD SERIES POWER SUPPLIES**

**with**

**Mach2 Host Controller**

**MODELS:**

**DuP(R)(D)10-.1-.3**

**DuP(R)(D)10-.5-1.5**

**DuP(R)(D)10-1-3**

**DuP(R)(D)10-3-6**

**DuP(R)(D)50-1-2**

**DuP(R)(D)60-.5-1**

## Table of Contents

<a href="#">1. Introduction</a>	<a href="#">11</a>
<a href="#">1.1. Two Year New Product Warranty</a>	<a href="#">11</a>
<a href="#">1.2. Contact Information</a>	<a href="#">12</a>
<a href="#">2. Safety Precautions</a>	<a href="#">16</a>
<a href="#">3. Functional Overview</a>	<a href="#">18</a>
<a href="#">4. Product Specifications</a>	<a href="#">19</a>
<a href="#">4.1. Input Power</a>	<a href="#">19</a>
<a href="#">4.2. Input Protection</a>	<a href="#">19</a>
<a href="#">4.3. Output Rating</a>	<a href="#">20</a>
<a href="#">4.4. Recommended Operating Range</a>	<a href="#">20</a>
<a href="#">4.5. Output Protection</a>	<a href="#">20</a>
<a href="#">4.6. Controls</a>	<a href="#">20</a>
<a href="#">4.7. On/Off Pulse Timing Generator</a>	<a href="#">21</a>
<a href="#">4.8. Fwd/Rev Direction Timing Generator</a>	<a href="#">21</a>
<a href="#">4.9. Environmental Conditions</a>	<a href="#">21</a>
<a href="#">4.10. Load Regulation</a>	<a href="#">21</a>
<a href="#">4.11. Line Regulation</a>	<a href="#">21</a>
<a href="#">4.12. Ripple</a>	<a href="#">21</a>
<a href="#">4.13. Meter Accuracy</a>	<a href="#">21</a>
<a href="#">4.14. Analog Interface Accuracy (option)</a>	<a href="#">22</a>
<a href="#">4.15. Cooling</a>	<a href="#">22</a>
<a href="#">4.16. Enclosure</a>	<a href="#">22</a>
<a href="#">4.17. Size</a>	<a href="#">22</a>
<a href="#">4.18. Weight</a>	<a href="#">22</a>
<a href="#">5. Installation Instructions</a>	<a href="#">23</a>

<a href="#">5.1. Power Input</a>	<a href="#">23</a>
<a href="#">5.1.1. Input Power Requirements</a>	<a href="#">23</a>
<a href="#">5.1.2. Input Power Connection</a>	<a href="#">23</a>
<a href="#">5.2. Mounting and Cooling Clearance Requirements</a>	<a href="#">23</a>
<a href="#">5.3. Output Power Connections</a>	<a href="#">23</a>
<a href="#">5.4. Remote MicroStar Connection (Optional)</a>	<a href="#">24</a>
<a href="#">5.5. Host Port Connections</a>	<a href="#">25</a>
<a href="#">5.5.1. RS485 Host Port Connections</a>	<a href="#">25</a>
<a href="#">5.5.2. USB Host/Service Port Connections</a>	<a href="#">25</a>
<a href="#">5.6. Digital I/O Connections</a>	<a href="#">26</a>
<a href="#">5.6.1. Digital Inputs</a>	<a href="#">27</a>
<a href="#">5.6.1.1. Interlock Enable</a>	<a href="#">27</a>
<a href="#">5.6.1.2. Operate Input</a>	<a href="#">27</a>
<a href="#">5.6.2. Digital Outputs</a>	<a href="#">28</a>
<a href="#">5.6.2.1. Operate Sense</a>	<a href="#">28</a>
<a href="#">5.6.2.2. Alarm Sense</a>	<a href="#">28</a>
<a href="#">5.7. Relay Connections (pump control) – (Option)</a>	<a href="#">29</a>
<a href="#">5.8. Analog I/O Connections (Option)</a>	<a href="#">30</a>
<a href="#">5.9. Master-Slave Connections – (Option)</a>	<a href="#">34</a>
<a href="#">5.9.1. Master-Slave Installation</a>	<a href="#">34</a>
<a href="#">6. Controls and Operation</a>	<a href="#">35</a>
<a href="#">6.1. MicroStar Panel Controls</a>	<a href="#">36</a>
<a href="#">6.1.1. Display</a>	<a href="#">37</a>
<a href="#">6.1.1.1. Flashing Display</a>	<a href="#">38</a>
<a href="#">6.1.1.2. Dual Range Output (option)</a>	<a href="#">38</a>
<a href="#">6.1.1.3. Dual Level Control (DPD, DuPD &amp; LFPD systems only)</a>	<a href="#">38</a>
<a href="#">6.1.1.4. Master-Slave Display Screens</a>	<a href="#">39</a>
<a href="#">6.1.1.5. Test Ref/Simulator Screens</a>	<a href="#">39</a>
<a href="#">6.1.2. VOLTS Meter and Controls</a>	<a href="#">40</a>

- [6.1.3. VOLTS Arrow Keys.....40](#)
- [6.1.3.1. P/S – Pause/Step for Recipe option.....40](#)
- [6.1.3.2. Right Arrow – Next Recipe Step for Recipe option.....40](#)
- [6.1.3.3. M/S – Master/Slave Menu for Master-Slave option.....40](#)
- [6.1.3.4. Flashing VOLTS Meter.....41](#)
- [6.1.4. AMPS Meter and Controls.....42](#)
- [6.1.4.1. Dual Range Output \(option\).....42](#)
- [6.1.5. AMPS Arrow Keys.....42](#)
- [6.1.5.1. INS, DEL - for Recipe Option.....42](#)
- [6.1.5.2. Flashing AMPS Meter.....43](#)
- [6.1.6. General Usage Keys.....44](#)
- [6.1.6.1. OPR – Operate Key.....44](#)
- [6.1.6.2. STBY – Standby Key.....44](#)
- [6.1.6.3. Arrow Keys and RTC and ATC Quick Set.....44](#)
- [6.1.6.4. ESC - Escape Key.....45](#)
- [6.1.6.5. ENTER - Enter Key.....45](#)
- [6.1.6.6. Number Keys.....45](#)
- [6.1.7. Menus.....46](#)
- [6.1.7.1. F1 – Function Key 1.....46](#)
- [1>RampMode\(option\).....46](#)
- [2>RampTime\(option\).....46](#)
- [3>RampOffset\(option\).....46](#)
- [4>TrickleLevel\(option\).....47](#)
- [5>TrickleEnable\(option\).....47](#)
- [6.1.7.2. CYCLE CNTL – Cycle Control Key.....48](#)

<a href="#"><u>1&gt;RealTimeCycle(RTC)</u></a> .....	<a href="#"><u>48</u></a>
<a href="#"><u>2&gt;AmpTimeCycle(ATC)</u></a> .....	<a href="#"><u>48</u></a>
<a href="#"><u>3&gt;RecipeCycle (option)</u></a> .....	<a href="#"><u>48</u></a>
<a href="#"><u>4&gt;RecipeLooping (option)</u></a> .....	<a href="#"><u>48</u></a>
<a href="#"><u>5&gt;ManualCycle</u></a> .....	<a href="#"><u>48</u></a>
<a href="#"><u>6&gt;RelayTripPoint (option)</u></a> .....	<a href="#"><u>49</u></a>
<a href="#"><u>7&gt;RelayOn Time (option)</u></a> .....	<a href="#"><u>49</u></a>
<a href="#"><u>8&gt;ViewTotalizer</u></a> .....	<a href="#"><u>49</u></a>
<a href="#"><u>9&gt;ClearTotalizer</u></a> .....	<a href="#"><u>49</u></a>
<a href="#"><u>10&gt;SubtractReverseAmpTime</u></a> .....	<a href="#"><u>49</u></a>
<a href="#"><u>6.1.7.3. SYS – System Key</u></a> .....	<a href="#"><u>50</u></a>
<a href="#"><u>1&gt;StatusandMiscSettings</u></a> .....	<a href="#"><u>50</u></a>
<a href="#"><u>2&gt;SetRegulationMode- (SETUP)</u></a> .....	<a href="#"><u>54</u></a>
<a href="#"><u>3&gt;SetCurr &amp; Volt Tol- (SETUP)</u></a> .....	<a href="#"><u>54</u></a>
<a href="#"><u>4&gt;SetResolutions- (SETUP)</u></a> .....	<a href="#"><u>54</u></a>
<a href="#"><u>5&gt;CalibrateSets/Reads (UNIT)</u></a> .....	<a href="#"><u>55</u></a>
<a href="#"><u>6&gt;SetPassword- (UNIT)</u></a> .....	<a href="#"><u>55</u></a>
<a href="#"><u>7&gt;SetControlSource- (UNIT)</u></a> .....	<a href="#"><u>55</u></a>
<a href="#"><u>6.1.7.4. PULSE TIMING – Pulse Timing Key</u></a> .....	<a href="#"><u>56</u></a>
<a href="#"><u>1&gt;SetFwdOnTime</u></a> .....	<a href="#"><u>56</u></a>
<a href="#"><u>2&gt;SetFwdOffTime</u></a> .....	<a href="#"><u>56</u></a>
<a href="#"><u>3&gt;SetForwardDuration(optionforreversingunits)</u></a> .....	<a href="#"><u>56</u></a>
<a href="#"><u>4&gt;SetReverseDuration(optionforreversingunits)</u></a> .....	<a href="#"><u>56</u></a>
<a href="#"><u>5&gt;SetRevOnTime(optionforpulsereversingunits)</u></a> .....	<a href="#"><u>56</u></a>
<a href="#"><u>6&gt;SetRevOffTime(optionforpulsereversingunits)</u></a> .....	<a href="#"><u>56</u></a>
<a href="#"><u>6.1.7.4.2. Minimum Pulse On Time for Pulsing Power Supplies</u></a> .....	<a href="#"><u>57</u></a>
<a href="#"><u>6.1.7.4.3. Dual Level Timing ( DPD, DuPD &amp; LFPD systems Only )</u></a> .....	<a href="#"><u>57</u></a>
<a href="#"><u>6.1.7.5. SAVE / RECALL – Save and Recall Key</u></a> .....	<a href="#"><u>58</u></a>

<a href="#">1&gt;SaveSetup</a> .....	<a href="#">58</a>
<a href="#">2&gt;RecallSetup</a> .....	<a href="#">58</a>
<a href="#">3&gt;DeleteSetup</a> .....	<a href="#">58</a>
<a href="#">4&gt;SaveRecipe</a> .....	<a href="#">58</a>
<a href="#">5&gt;RecallRecipe(option)</a> .....	<a href="#">58</a>
<a href="#">6&gt;DeleteRecipe(option)</a> .....	<a href="#">58</a>
<b><a href="#">6.1.7.6. ALARM / SILENCE – Alarm Key</a></b> .....	<b><a href="#">59</a></b>
<a href="#">1&gt;EndOfCycleAlarm</a> .....	<a href="#">59</a>
<a href="#">2&gt;CurrentToleranceErrorAlarm</a> .....	<a href="#">59</a>
<a href="#">3&gt;VoltageToleranceErrorAlarm</a> .....	<a href="#">59</a>
<a href="#">4&gt;RelayOutputOnAlarm(option)</a> .....	<a href="#">59</a>
<b><a href="#">6.1.7.7. M/S - Master/Slave Menu Key (Volts Down key) - (Option)</a></b> .....	<b><a href="#">60</a></b>
<a href="#">1&gt;SendAll M/S Settings</a> .....	<a href="#">60</a>
<a href="#">2&gt;SendAll But Levels</a> .....	<a href="#">60</a>
<a href="#">3&gt;SendTimingOnly</a> .....	<a href="#">60</a>
<b><a href="#">6.2. Programming</a></b> .....	<b><a href="#">61</a></b>
<b><a href="#">6.2.1. Setups</a></b> .....	<b><a href="#">61</a></b>
<a href="#">6.2.1.1. Saving Setups</a> .....	<a href="#">62</a>
<a href="#">6.2.1.2. Recalling Setups</a> .....	<a href="#">62</a>
<a href="#">6.2.1.3. Deleting Setups</a> .....	<a href="#">62</a>
<b><a href="#">6.2.2. Recipes</a></b> .....	<b><a href="#">63</a></b>
<a href="#">6.2.2.1. Recipe Edit Mode - for Editing Recipes</a> .....	<a href="#">63</a>
<a href="#">6.2.2.1.1. Edit Recipe Keys for Recipe Edit Mode</a> .....	<a href="#">64</a>
<a href="#">6.2.2.2. Recipe Mode</a> .....	<a href="#">65</a>
<a href="#">6.2.2.2.1. Editing Setups in Recipe Mode</a> .....	<a href="#">66</a>
<a href="#">6.2.2.2.2. Canceling Recipe Mode</a> .....	<a href="#">66</a>
<a href="#">6.2.2.3. Saving, Recalling and Deleting Recipes</a> .....	<a href="#">66</a>
<a href="#">6.2.2.4. Running a Recipe</a> .....	<a href="#">66</a>
<a href="#">6.2.2.5. Looping Recipe Steps</a> .....	<a href="#">67</a>
<a href="#">6.2.2.5.1. Editing Loops</a> .....	<a href="#">67</a>
<b><a href="#">6.3. Host Control</a></b> .....	<b><a href="#">69</a></b>
<a href="#">6.3.1. Host Ports</a> .....	<a href="#">69</a>

<a href="#">6.3.2. Host Port Connections</a>	<a href="#">69</a>
<a href="#">6.3.3. Host Port Communications Settings</a>	<a href="#">69</a>
<a href="#">6.3.4. Host Protocol</a>	<a href="#">69</a>
<a href="#">6.3.5. Host User Interface</a>	<a href="#">69</a>
<a href="#">6.3.6. LabVIEW Driver</a>	<a href="#">70</a>
<a href="#">6.4. Analog Control (option)</a>	<a href="#">71</a>
<a href="#">6.4.1. Analog Control Connections</a>	<a href="#">71</a>
<a href="#">6.4.2. Analog Output Readbacks</a>	<a href="#">71</a>
<a href="#">6.4.3. Analog Input Setting Control</a>	<a href="#">72</a>
<a href="#">6.4.4. Analog Regulation Modes</a>	<a href="#">72</a>
<a href="#">6.4.5. Analog Control Modes</a>	<a href="#">73</a>
<a href="#">6.4.6. Remote Operate / Standby for Analog Control</a>	<a href="#">73</a>
<a href="#">6.4.7. Dual Range Output (DRO) and Analog Control</a>	<a href="#">73</a>
<a href="#">6.5. Power Fail Operation</a>	<a href="#">74</a>
<a href="#">6.6. Options</a>	<a href="#">74</a>
<a href="#">6.6.1. RMP - Ramp Function</a>	<a href="#">74</a>
<a href="#">6.6.2. RLY - Relay Output Control</a>	<a href="#">74</a>
<a href="#">6.6.3. ANL - Analog Control</a>	<a href="#">75</a>
<a href="#">6.6.4. RCP - Recipe Control</a>	<a href="#">75</a>
<a href="#">6.6.5. TKL - Trickle Mode</a>	<a href="#">75</a>
<a href="#">6.6.6. MSV - Master-Slave Control</a>	<a href="#">75</a>
<a href="#">6.6.7. DRO – Dual Range Output</a>	<a href="#">76</a>
<a href="#">6.7. Messages</a>	<a href="#">76</a>
<a href="#">6.7.1. Msg01 I Limit: &gt;100ms</a>	<a href="#">76</a>
<a href="#">6.7.2. Msg02 I Limit: Sum &gt; Ave</a>	<a href="#">76</a>
<a href="#">6.7.3. Msg03 I Limit: V Reg Duty</a>	<a href="#">76</a>
<a href="#">6.7.4. Timing Params Not Valid, Please Recheck Them</a>	<a href="#">77</a>
<a href="#">6.7.5. M-S Err: message</a>	<a href="#">77</a>
<a href="#">6.7.6. CM Power Fail Standby - Restarting When Power OK</a>	<a href="#">77</a>

6.7.7. Ext. Interlock Is Open - Cannot Operate.....	77
6.7.8. Power Fail Save Error, Call Dynatronix Service.....	77
6.7.9. Settings Defaulted.....	77
<b>6.8. Quick Start Guide.....</b>	<b>78</b>
6.8.1. Quick-Start Setup Tips.....	78
6.8.1.1. PULSE TIMING Menu Key.....	78
6.8.1.2. Output Settings Keys.....	79
6.8.1.3. CYCLE CNTRL Menu Key.....	79
6.8.1.4. SYS Menu Key.....	80
6.8.1.5. SAVE / RECALL Key.....	80
6.8.1.6. ALARM / SILENCE Key.....	80
6.8.1.7. F1 Key.....	81
6.8.2. Settings and Operation Examples.....	81
6.8.2.1. DC output test (all units).....	81
6.8.2.2. Reversing only output test (DCR, reversing only units only).....	82
6.8.2.3. Pulsing output test (DP, pulsing units only).....	83
6.8.2.4. Pulse Reverse output test (DPR, pulse reverse units only).....	83
6.8.2.5. Real Time Controlled (RTC) cycle setup.....	84
6.8.2.6. Amp Time Controlled (ATC) cycle setup.....	84
6.8.2.7. Using Setups.....	85
6.8.2.8. Creating a Recipe.....	86
6.8.2.9. Using System Settings.....	87
6.8.2.9.1. Set the Regulation Mode.....	87
6.8.2.9.2. Set the Current and Voltage Tolerance.....	87
6.8.2.9.3. Set the desired Settings Resolutions.....	88
6.8.3. MicroStar Pulse Setup and Recipe Worksheets.....	89
6.8.3.1. Setup Settings Worksheet.....	90
6.8.3.2. Recipe Settings Worksheet.....	91
<b>7. Calibration.....</b>	<b>92</b>
<b>7.1. Overview.....</b>	<b>92</b>



<a href="#">7.2. Equipment</a>	<a href="#">93</a>
<a href="#">7.2.1. Meter(s)</a>	<a href="#">93</a>
<a href="#">7.2.2. Current Shunt</a>	<a href="#">93</a>
<a href="#">7.2.3. Loads</a>	<a href="#">94</a>
<a href="#">7.3. Output Calibration</a>	<a href="#">95</a>
<a href="#">7.3.1. Setup</a>	<a href="#">95</a>
<a href="#">7.3.2. Current Output Calibration - Forward</a>	<a href="#">96</a>
<a href="#">7.3.3. Current Output Calibration – Reverse (option)</a>	<a href="#">96</a>
<a href="#">7.3.4. Current Output Dual Range Calibration, Range 1 (low range)</a>	<a href="#">97</a>
<a href="#">7.3.5. Voltage Output Cal Forward</a>	<a href="#">98</a>
<a href="#">7.3.6. Voltage Output Cal Reverse (option)</a>	<a href="#">98</a>
<a href="#">7.4. Analog Calibration (option)</a>	<a href="#">99</a>
<a href="#">7.4.1. Setup -- 4-20mA, 0-5v or 0-10v Interface</a>	<a href="#">99</a>
<a href="#">7.4.2. Analog Channel Calibration</a>	<a href="#">100</a>
<a href="#">8. Optional Special Features</a>	<a href="#">103</a>
<a href="#">9. Spare Parts and Reference Documentation</a>	<a href="#">104</a>
<a href="#">9.1. Spare Parts List</a>	<a href="#">104</a>
<a href="#">9.2. Reference Document List</a>	<a href="#">104</a>
<a href="#">A. Menu Flow Chart</a>	<a href="#">105</a>
<a href="#">B. Mach2 Host Protocol</a>	<a href="#">114</a>
<a href="#">B.1. Alphabetical Command Character List</a>	<a href="#">114</a>
<a href="#">B.2. Formatting and Communications Rules</a>	<a href="#">115</a>
<a href="#">B.3. Command Format</a>	<a href="#">117</a>
<a href="#">B.4. Communications Settings – RS485</a>	<a href="#">118</a>
<a href="#">B.5. Communications Settings – USB</a>	<a href="#">119</a>
<a href="#">B.6. CRC Calculation</a>	<a href="#">120</a>
<a href="#">B.7. ACK Response Command</a>	<a href="#">121</a>

<a href="#">B.8. Alarm and Error Status Command:</a>	<a href="#">122</a>
<a href="#">B.9. Available Recipes Command:</a>	<a href="#">124</a>
<a href="#">B.10. Available Setups Command:</a>	<a href="#">125</a>
<a href="#">B.11. Calibration Analog Command:</a>	<a href="#">126</a>
<a href="#">B.12. Calibration Output &amp; Meters Command:</a>	<a href="#">129</a>
<a href="#">B.13. CRC Disable/Enable Command:</a>	<a href="#">132</a>
<a href="#">B.14. Delimiter Text Disable/Enable Command:</a>	<a href="#">133</a>
<a href="#">B.15. NAK Response Command:</a>	<a href="#">134</a>
<a href="#">B.16. Readings Command:</a>	<a href="#">136</a>
<a href="#">B.17. Recipe Command:</a>	<a href="#">138</a>
<a href="#">B.18. Setup Command:</a>	<a href="#">141</a>
<a href="#">B.19. State Command:</a>	<a href="#">145</a>
<a href="#">B.20. Unit Command:</a>	<a href="#">147</a>
<a href="#">B.21. User Settings Command:</a>	<a href="#">150</a>
<a href="#">B.22. Protocol Revision History:</a>	<a href="#">153</a>
<a href="#">C. Pulse Mathematics:</a>	<a href="#">155</a>
<a href="#">C.1. Pulse Plating Calculations:</a>	<a href="#">155</a>
<a href="#">C.1.1. Overview - DC versus Pulse:</a>	<a href="#">155</a>
<a href="#">C.1.2. Duty Cycle for Pulse:</a>	<a href="#">156</a>
<a href="#">C.1.3. Peak Regulation:</a>	<a href="#">157</a>
<a href="#">C.1.4. Average Readbacks:</a>	<a href="#">157</a>
<a href="#">C.1.5. Ampere-Time for Pulse Plating:</a>	<a href="#">158</a>
<a href="#">C.1.6. Real Time Control for Pulse Plating:</a>	<a href="#">158</a>
<a href="#">C.2. Periodic Reverse (PR) Plating Calculations:</a>	<a href="#">158</a>
<a href="#">C.2.1. Duty Cycle for PR:</a>	<a href="#">158</a>
<a href="#">C.2.2. Ampere-Time Preset for PR:</a>	<a href="#">160</a>
<a href="#">C.2.3. Real-Time Preset for PR:</a>	<a href="#">161</a>
<a href="#">C.2.4. Reverse Deplating Ratio:</a>	<a href="#">162</a>

[C.2.5. Dead Time for PR](#).....[162](#)  
[D. Revision History](#).....[163](#)

---

# 1. Introduction

---

## 1.1. Two Year New Product Warranty

---

DYNATRONIX, INC., hereby warrants to the purchaser that all new products sold are guaranteed against defects in materials or manufacture for two years after shipment. DYNATRONIX, INC., expressly reserves the right to offer an extended warranty at its sole discretion. Such express warranty shall not be deemed effective unless expressly authorized by DYNATRONIX, INC., personnel. DYNATRONIX, INC., at its sole discretion, will repair or replace any defective products that are returned in accordance within the time period proscribed by this warranty.

All products for repair or examination must be returned to DYNATRONIX, INC., prepaid. The defective product, as repaired or replaced, requires the issuance of a Return Material Authorization Number ("RMA") from DYNATRONIX, INC., personnel prior to acceptance for repair or replacement by DYNATRONIX, INC. An RMA will be issued upon determination by DYNATRONIX, INC., personnel that the defective product requires factory repair. The customer assumes all shipment expenses of the returned product to and from DYNATRONIX, INC., within the warranty period.

DYNATRONIX, INC.'s liability, under this warranty, shall in any event not exceed the original purchase price of the product. To make a claim under this warranty, it is the responsibility of the purchaser to immediately contact DYNATRONIX, INC., and provide proof of the product's model, part number, input and output voltage and serial number. DYNATRONIX, Inc., will then determine whether the product remains under warranty.

This warranty **DOES NOT COVER** failures caused by any of the following:

1. Misuse, negligence or accident;
2. Alterations made by individuals or parties not directly employed by DYNATRONIX, INC.

This warranty **DOES NOT EXTEND** to commercial sub assemblies that are guaranteed by a manufacturer's warranty.

This warranty becomes effective upon the date the product is shipped. In the event that a product no longer covered by the NEW PRODUCT WARRANTY is sent for repair, the provisions of the REPAIR WARRANTY as detailed below govern.

**DYNATRONIX, INC., EXPRESSLY DISCLAIMS ALL OTHER WARRANTIES, INCLUDING, WITHOUT LIMITATION, ALL EXPRESS WARRANTIES, THE IMPLIED WARRANTY OF FITNESS FOR A PARTICULAR PURPOSE AND THE IMPLIED WARRANTY OF MERCHANTABILITY. THERE ARE NO WARRANTIES WHICH EXTEND BEYOND THE DESCRIPTION ON THE FACE HEREOF.**

### REPAIR WARRANTY

DYNATRONIX, INC., hereby warrants to the purchaser that products previously purchased as new from DYNATRONIX, INC., and returned to DYNATRONIX, INC., for repair or replacement be hereby governed by the provisions of the REPAIR WARRANTY. DYNATRONIX, INC., expressly reserves the right to extend the REPAIR WARRANTY to products not purchased from DYNATRONIX, INC., at its sole discretion. The REPAIR WARRANTY shall exclude all products not purchased from DYNATRONIX, INC., unless expressly authorized by DYNATRONIX, INC., personnel.

DYNATRONIX, INC., guarantees that all repairs be free from defects for ninety (90) days after return shipment to purchaser. Product failures not related to repairs done by DYNATRONIX, INC., shall not be covered by the REPAIR WARRANTY. DYNATRONIX, INC., further warrants that repair investigations that fail to identify product defects shall be guaranteed for a ninety (90) day period after return shipment to customer. In the event that the product fails within the stated ninety (90) day period after the inspection, DYNATRONIX, INC., agrees to assume the in out freight costs for subsequent returns of the product, experiencing the complained of problem, for an additional ninety (90) day period.

Effective Date: January 1, 2006

## 1.2. Contact Information

---

### USA Sales

#### Corporate Headquarters

**Dynatronix, Inc**  
462 Griffin Boulevard  
Amery, Wisconsin 54001 USA

Telephone: (715) 268-8118  
FAX: (715) 268-8183  
Toll-Free USA: (800) 826-7172  
[www.dynatronix.com](http://www.dynatronix.com)

**Customer Support**  
**Dynatronix, Inc**  
462 Griffin Boulevard  
Amery, Wisconsin 54001 USA

Telephone: (715) 268-8118  
FAX: (715) 268-8183  
Toll-Free USA: (800) 826-7172  
[techsupport@dynatronix.com](mailto:techsupport@dynatronix.com)  
[www.dynatronix.com](http://www.dynatronix.com)

---

## 2. Safety Precautions

---

Before proceeding any further through this manual, this section should be read thoroughly to protect yourself and your equipment.

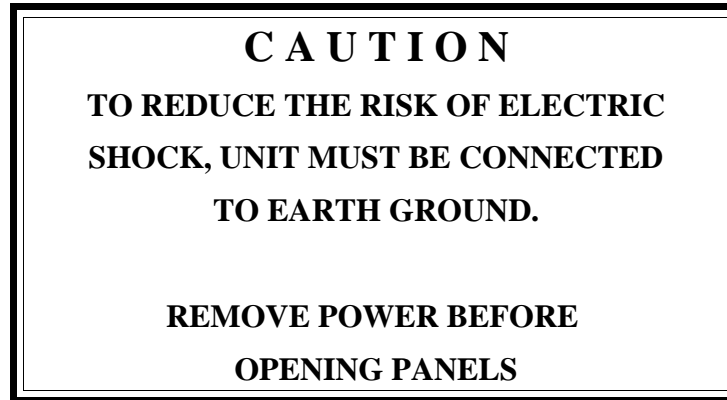

1. To properly operate this power supply, only electric cords with a 3-prong grounded system are to be used.
2. The electric cord providing power to the machine should be plugged in only to a grounded outlet that complies with U.L. and/or OSHA safety requirements, or local regulations.
3. If necessary to work inside the cabinet, remember to remove AC power before opening any panels. Not doing so may endanger yourself and your equipment. The means of disconnecting the power supply is either the removal of the detachable power supply cord from the power inlet or power receptacle or both. If the power cord is direct connected to the AC source as well as the power supply, turn off the local safety or power panel branch breaker which provides AC to the power supply. Follow your lock out / tag out procedures to ensure that power is not unexpectedly applied while servicing.
4. This unit contains no user serviceable parts. All repairs or modifications to this unit must be done at the Dynatronix factory, or at an authorized Dynatronix Service Center, or by a qualified service technician. See the Table of Contents section for a list of authorized service centers in the USA and Europe.
5. If necessary to work inside of cabinet with power on DO NOT wear metal objects on hands or wrists because of the various DC and AC voltages present.
6. The following symbol indicates a protective earth connection.

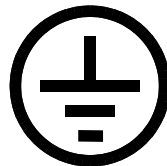

7. The symbol below means that the product manual should be consulted for additional information.



8. The following label indicates where high AC or DC voltages are located inside of the unit. Be aware of these locations if power is needed for any work being done inside of unit. Not doing so may endanger yourself and your equipment.

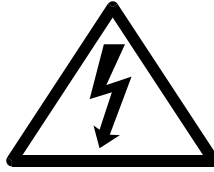

9. The label below indicates where components or surfaces are operating at temperatures which might cause injury either directly (burn) or indirectly (involuntarily moving body into



another danger). This label is used most often on the output transistor heatsinks.

10. If this power supply weighs more than 40lb / 18kg (see Section 4 - Specifications), it must be lifted by two persons. Always use proper lifting technique.

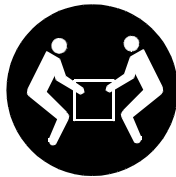

11. Use of this product for purposes other than those specified in this manual is not recommended. Use for other purposes may give unexpected results or cause damage to the power supply and/or the system it is being used in.

---

## 3. Functional Overview

---

The Dynatronix Micro Pulse Series ( DuP / DuPR / DuPD ) with MicroStar interface are peak voltage or current regulating, pulse (DP) pulse reversing (DPR) and dual level (DPD) power supplies designed for the electroplating industry.

The DuP/DuPR/DuPD front panel control consists of the MicroStar interface. The MicroStar interface features large, easy-to-read digital displays for both amps and volts as well as a third digital display and a soft-touch keypad for setting additional features.

Operation with the MicroStar is quick. With a press of some buttons, the operator sets desired output levels and pulse timing parameters for the rectifier. Additional first time parameters can be entered using the soft-touch keypad with the digital display guiding the operator through the setup of ampere time cycles, real time cycles, regulation mode, and auxiliary timer settings. Once these settings are entered, the data is saved in the on-board memory of the rectifier. Simply pressing the "Operate" button activates the plating cycle using the parameters retained in the memory. With the ability to save and recall up to 10 different process settings, the MicroStar Interface makes it easy to plate a variety of parts.

Some standard features of the DuP/DuPR/DuPD Series include an RS485 host port, a USB host/service port, an ampere-time totalizer; a voltage/current limit indicator; built-in calibration, fault detection circuitry, real time control and ampere-time control with local alarm; Optional features include: output ramp up or down; recipe control with up to 8 steps plus looping ability; analog interface control (for PLC control); timer-controlled relay contacts; Master-Slave; Dual Range output; and remote front panel capabilities. As with all the MicroStar interface controls upgrading from the standard capabilities to: "Ramp Timer", Relay control, Recipe control or Analog control can easily be added in the field or during the initial assembly at the factory.

The MicroStar controller is Flash memory based and will allow upgrading firmware in the field using a computer with a USB port.

A computer program called FrontPanel+ is included for use as a basic user interface for computer control. It can send settings and show readings using either the RS485 or USB host ports. It also has basic data logging capability.

The DuP/DuPR/DuPD Series is available in bench top configuration with models ranging from 0.1 to 6 peak amps at 10 volts. Several options are available for AC input power.



## 4. Product Specifications

<p><b>4.1. Input Power</b></p>	<p><b>Standard:</b> 110-120 Vac Single Phase 50-60hz w/single fuse and one spare</p> <p><b>Standard:</b> 208-240 Vac Single Phase 50-60hz w/dual fuses (Dual fusing is required for units shipped to Europe)</p>		
	<b>MODEL</b>	<b>110-120VAC</b>	<b>208-240VAC</b>
	DuP(R)(D)10-.1-.3	1 AMP	.5 AMP
	DuP(R)(D)10-.5-1.5	1 AMP	.5 AMP
	DuP(R)(D)10-1-3	1 AMP	.5 AMP
	DuP(R)(D)10-3-6	1 AMP	.5 AMP
	DuP(R)(D)50-1-2	1.1 AMP	.5 AMP
	DuP(R)(D)60-.5-1	1 AMP	1 AMP
<p><b>4.2. Input Protection</b></p>	<p><b>Main:</b> On/Off switch with a fuse inside power module. See below for fuse ratings. Located on back panel. (The fuse is inside the small drawer that slides out underneath power cord connection. Use a small screwdriver to remove.)</p> <p><b>Note:</b> The arrow underneath the drawer should align with the arrow of the input power configuration. For example if the unit is wired for a 110/120V input the 110/120V arrow on the drawer will need to be aligned with the arrow underneath the drawer.)</p> <p><b>Control Power:</b> Additional fuses located internally on the base and on a PCB.</p>		
	<b>MODEL</b>	<b>110-120VAC</b>	<b>208-240VAC</b>
	DuP(R)(D)10-.1-.3	1.25 AMP	1 AMP
	DuP(R)(D)10-.5-1.5	1.25 AMP	1 AMP
	DuP(R)(D)10-1-3	1.25 AMP	1 AMP

<b>4.3. Output Rating</b>	DuP(R)(D)10-3-6	1.25 AMP	1 AMP
	DuP(R)(D)50-1-2	1.25 AMP	1 AMP
	DuP(R)(D)60-.5-1	1.25 AMP	1.25 AMP
	<b>MODEL</b>	<b>OUTPUT RATING</b>	
	DuP(R)(D)10-.1-.3	0-10V, 0.1A avg, 0.3A peak	
	DuP(R)(D)10-.5-1.5	0-10V, 0.5A avg, 1.5A peak	
	DuP(R)(D)10-1-3	0-10V, 1A avg, 3A peak	
	DuP(R)(D)10-3-6	0-10V, 3A avg, 6A peak	
	DuP(R)(D)50-1-2	0-50V, 1A avg, 2A peak	
	DuP(R)(D)60-.5-1	0-60V, 0.5A avg, 1A peak	
<b>4.4. Recommended Operating Range</b>	<b>MODEL</b>	<b>DC Output Range</b>	
	DuP(R)(D)10-.1-.3	1.00V-10.0V 0.03A-0.3A Peak	
	DuP(R)(D)10-.5-1.5	1.00V-10.0V 0.15A-1.50A Peak	
	DuP(R)(D)10-1-3	1.00V-10.0V 0.30A-3.00A Peak	
	DuP(R)(D)10-3-6	1.00V-10.0V 0.60A-6.00A Peak	
	DuP(R)(D)50-1-2	5.00V-50.0V 0.20A-2.00A Peak	
	DuP(R)(D)60-.5-1	6.00V-60.0V 0.10A-1.00A Peak	

<p><b>4.5. Output Protection</b></p>	<p>The internal controller will not accept commands that will exceed the output rating of the power supply. Short circuit protected.</p>
<p><b>4.6. Controls</b></p>	<p>MicroStar Panel (display, key-pad entry). RS485 Host Port. USB Host/Service Port User Interface Program – FrontPanel+. Digital I/O Interface. Analog I/O Interface (optional).</p>

<p><b>4.7. On/Off Pulse Timing Generator</b></p> <hr/>	There are 4 On/Off timing ranges available		
	<b>Range</b>	<b>On Time</b>	<b>Off Time</b>
	1	00.06msec -99.99msec	00.06msec -99.99msec
	2	000.1msec-999.9msec	000.1msec-999.9msec
	3	0.001sec-9.999sec	0.001sec-9.999sec
	4	00.01sec-99.99sec	00.01sec-99.99sec
On time settings of "0" will result in no output. Off time settings of "0" will result in a DC output.			
<p><b>4.8. Fwd/Rev Direction Timing Generator</b></p> <hr/> <p>(OPTION FOR REVERSING UNITS)</p>	There are 4 On/Off timing ranges available		
	<b>Range</b>	<b>On Time</b>	<b>Off Time</b>
	1	00.06msec -99.99msec	00.06msec -99.99msec
	2	000.1msec-999.9msec	000.1msec-999.9msec
	3	0.001sec-9.999sec	0.001sec-9.999sec
	4	00.01sec-99.99sec	00.01sec-99.99sec
Reverse time settings of "0" will result in forward only output and vice versa.			
<p><b>4.9. Environmental Conditions</b></p> <hr/>	<p>INDOOR USE ONLY</p> <p>Operating temperature: 10 - 40C.</p> <p>Storage temperature: -20 - 85C.</p>		
<p><b>4.10. Load Regulation</b></p> <hr/>	<p>Current: +/- 0.5% from 10% -100% load</p> <p>Voltage: +/- 0.5% from 10% - 100% load</p>		
<p><b>4.11. Line Regulation</b></p> <hr/>	<p>For line conditions as listed in <b>4.1. Input Power</b></p> <p>Current: +/- 0.5%</p> <p>Voltage: +/- 0.5%</p>		
<p><b>4.12. Ripple</b></p> <hr/>	<p>No more than 2% RMS of maximum rated output Voltage.</p>		
<p><b>4.13. Meter Accuracy</b></p> <hr/>	<p>+/- 1% plus +/- One Least Significant Digit</p> <p>Resolution: (reads average value)</p> <p>Voltage: 00.1V and 0.01V Auto Ranging</p> <p>Current: 1.000 to 3.000 Amps: 0.001A</p> <p>0.100 to 0.5 Amps: 000.1mA</p>		

<b>4.14. Analog Interface Accuracy (option)</b>	Setting and Readback: +/- .1% of maximum setting/readback or +/- 1% of setting whichever is greater.
<b>4.15. Cooling</b>	Natural convection cooling. Do not block the cooling fins on the rear panel.
<b>4.16. Enclosure</b>	White powder coated front panel and cabinet with tilt up bail on the bottom for easier viewing.
<b>4.17. Size</b>	12"W x 5.85"H x 13.5"D 305mm x 149mm x 343mm
<b>4.18. Weight</b>	Approximately 15 lbs / 7 kg

## 5. Installation Instructions

### 5.1. Power Input

#### 5.1.1. Input Power Requirements

The MicroStar Series Rectifier is designed for operation from 110VAC or 220VAC 1-phase, 50-60 Hz, primary power.. Check the label on the rear of the unit for proper input power requirements. See Section 4.2 for checking the input voltage setting.

The output capacity of each rectifier is specified on the equipment serial tag located on the back of the unit. This equipment requires grounding in accordance with local regulations.

#### 5.1.2. Input Power Connection

Connect the power cord to the correct supply in accordance with U.L. and/or OSHA specifications or local requirements. Make sure the connections are made with power OFF and under no load.

### 5.2. Mounting and Cooling Clearance Requirements

The MicroStar Series Rectifier is designed for shelf mounting.

Cooling is by natural convection. Do not block airflow around the cooling fins on the rear of the power supply.

### 5.3. Output Power Connections

Located at the rear of the DuP(R) MicroStar series is a two contact terminal strip which is used to connect to the bath. Make sure the connections are tight to reduce heating.

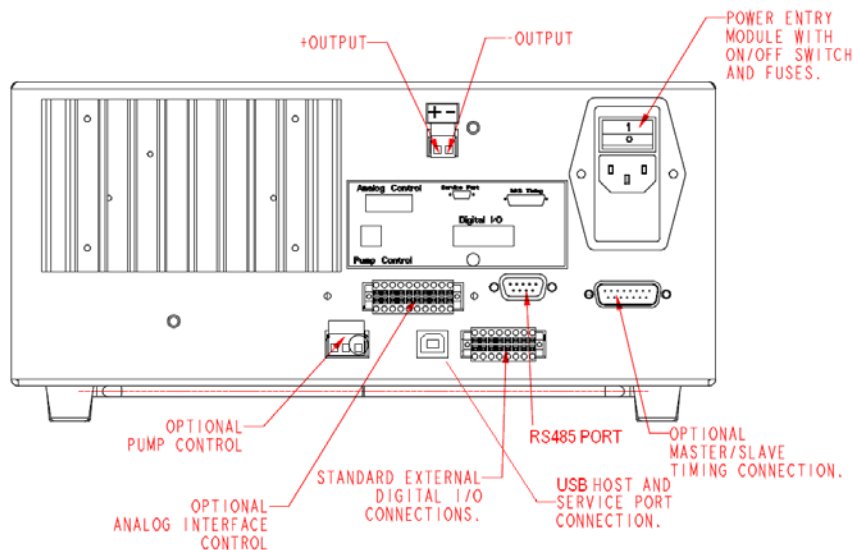

Figure 5.1: Rear Panel

### 5.4. Remote MicroStar Connection (Optional)

Connect the Remote MicroStar to the power supply with the supplied RJ45 cat5 patch cable supplied. The connection at the Remote MicroStar is on the bottom or rear of the enclosure. The connection to power supply main unit is on the rear of the unit.



Figure 5.2: MicroStar Remote Cat5 Cable

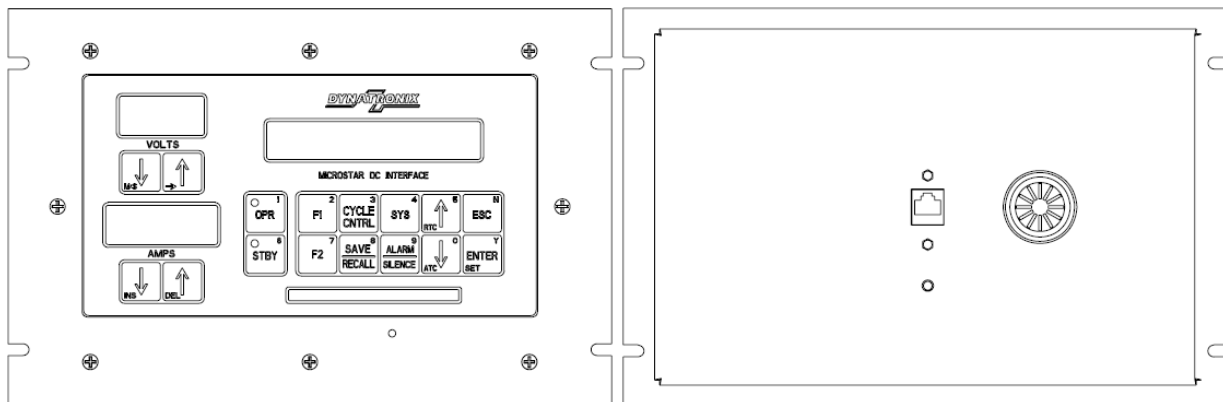

Figure 5.3: Remote MicroStar Panel: Front & Rear Views

## 5.5. Host Port Connections

The MicroStar Series rectifier can be controlled and monitored by a host (computer, PLC, etc). The host port can be used to monitor and/or control the MicroStar power supply using the ASCII Host Protocol (See section 6.3 Host Control and Appendix B Mach2 Host Protocol for more information).

### 5.5.1. RS485 Host Port Connections

The serial host port supports a half duplex RS485 interface. Multiple MicroStar power supplies can be connected to a single RS485 bus (multi-drop). Each device on the RS485 bus is individually addressed using the ASCII Host Protocol. If an RS232 device (such as a PC) will be connected to the MicroStar host port then an RS232 to RS485 converter module is required (not included). See section 6.3 Host Control for host port operation and more information.

Make sure the connections to the host match the signals shown below.

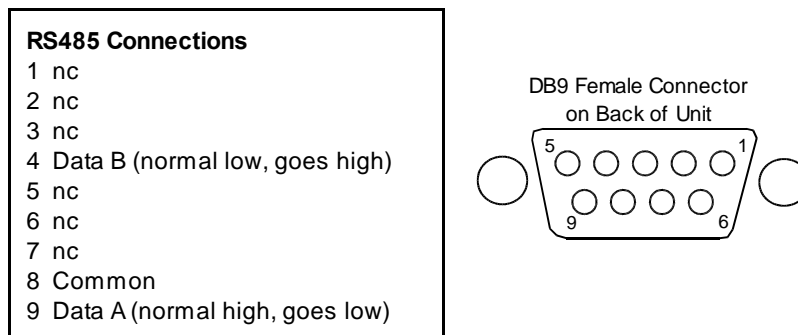

Figure 5.4: RS485 Wiring Connections

Connecting multiple MicroStar power supplies to a single RS485 network will require Y cables – 2 Male to 1 Female DB9 (Dynatronix#020-0005-07) in order to “daisy chain” the RS485 Host Ports. These Y cables can also be purchased at PCCABLES.COM, Part No.00828, or any similar (9 pin D, 1 F x 2 M) strait-through Y cable can be used. The cables between each unit can be a standard strait-through serial cable.

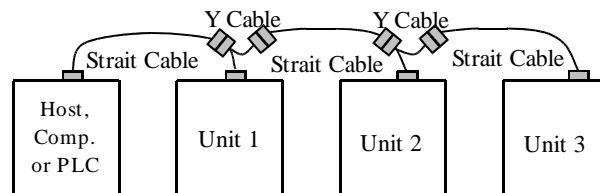

Figure 5.5: RS485 Host Connections with 3 Units

### 5.5.2. USB Host/Service Port Connections

The Host/Service USB port can be used as a single connection, short run, Host port. It is also used for downloading firmware upgrades. The USB connection uses a Type B connector. See Appendix B.5 Communications Settings – USB for more information on using the USB port.



## 5.6. Digital I/O Connections

Figure 5.6 shows the Digital Input/Output connector with labels showing the signals on each terminal. When attaching wires to the connector use a 2.5mm (0.1") flat blade screwdriver inserted into the square opening (blade horizontal) to release the wire clamp. Insert the wire into the round hole next to the screwdriver. Remove the screwdriver to clamp the wire in place.

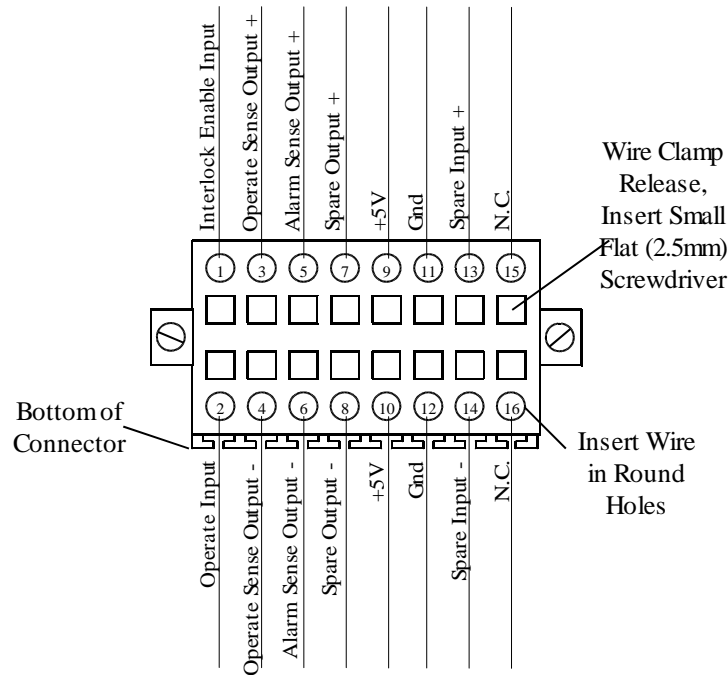

Figure 5.6: Digital I/O Connector

---

### 5.6.1. Digital Inputs

---

The two standard digital inputs are the Interlock Enable input and the Operate input.

#### 5.6.1.1. Interlock Enable

---

The Interlock Enable input (Pin 1) when tied to Gnd (Pin 9) allows for proper operation of the supply. When this connection is open supply operation is disabled. If the supply is operating when this input is opened the unit will go into standby and a message will be displayed.

#### 5.6.1.2. Operate Input

---

The Operate input (Pin 2) when tied to Gnd (Pin 10) activates the output of the supply (Remote Operate/Standby). NOTE: This input must be used to control the output when using the **SYS**, 7>SetControlSource 3>SetAnalogCntrlMode menu item. It is optional in all other modes.

SEE: Section 6.1.7.3 **SYS – System Key**, 1>StatusandMiscSettings 4>ExtOPRInputOptionsfor more information on the options for using this input.

When any one of these digital inputs are closed, the current flowing through the corresponding circuit will be less than 15mA.

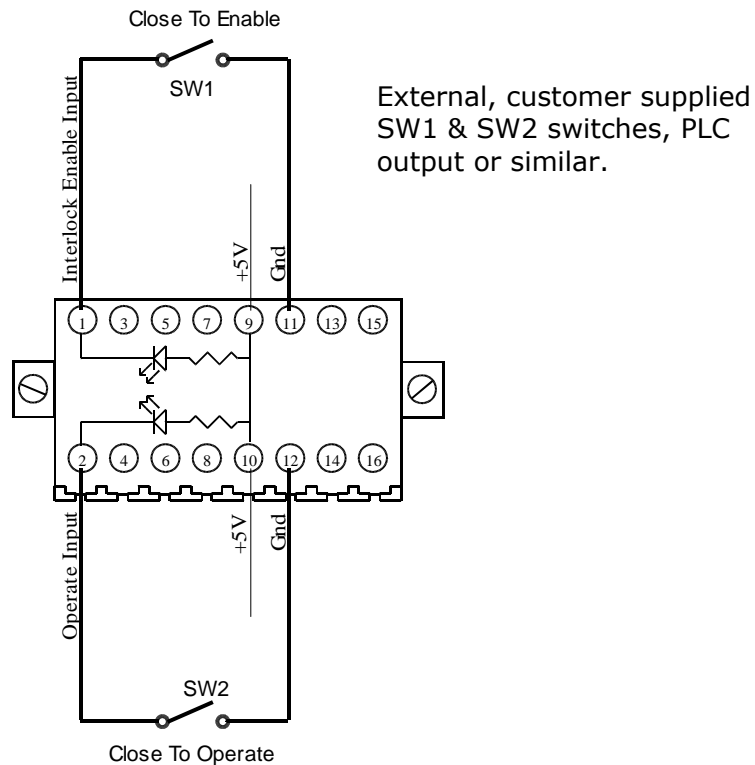

Figure 5.7: Digital Input Connections

## 5.6.2. Digital Outputs

The two standard digital outputs are the Operate Sense and the Alarm Sense.

### 5.6.2.1. Operate Sense

The Operate Sense (Pins 3 & 4) when configured as shown below can be used to sense whether the unit is in the Operate or Standby condition. The Operate condition will cause current flow thru the circuit and the external opto-coupler shown will be in the "on" state.

### 5.6.2.2. Alarm Sense

The Alarm Sense (Pins 5 & 6) when configured as shown in **Figure 5.8** below can be used to sense if an alarm condition has occurred. An alarm condition will cause current to flow thru the circuit and the external opto-coupler shown will be in the "on" state.

A different voltage source can be applied to the Alarm Sense + (Pin 5) and Operate Sense + (Pin 3) output pins. If the voltage is greater than 5 volts it must have an external current limit resistor to limit the current to 15mA. The maximum voltage allowed on the + input or - output pins is 24V DC.

The maximum current flow through either of the digital outputs is 15mA.

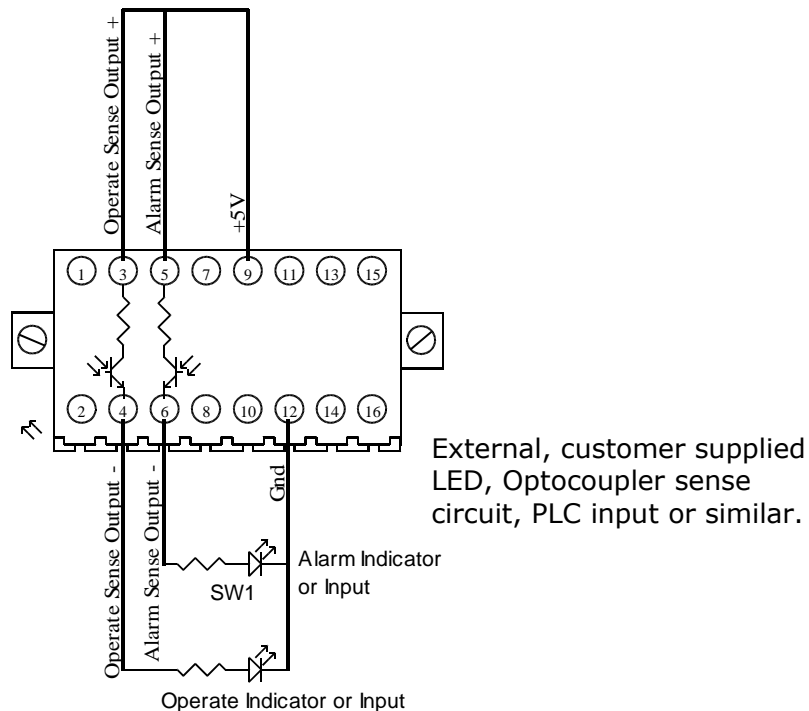

**Figure 5.8: Digital Output Connections**

## 5.7. Relay Connections (pump control) – (Option)

The optional relay output can be used to control a chemical pump. It can also be set up as an output that is on while the unit is in operate or to be on when there is an alarm condition. See Section 6.1.7.3 **SYS – System Key**, 1>StatusandMiscSettings 5>RelayControl Optionsand 6.1.7.2 **CYCLE CNTL – Cycle Control Key** relay items for more details.

The relay connections are the 3 position terminal strip at the rear of the control enclosure. **Figure 5.9** shows the connection points for the relay to control an external device. Relay contacts, common to normally closed, open when the condition controlling the relay is active. Relay contacts, common to normally open, close when the condition is active.

The ratings for the relay contacts are 12 Amps at 125 Volts AC/DC. The terminals accept 24 to 12 gauge wire.

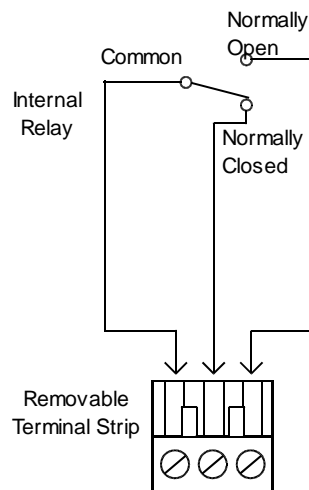

Figure 5.9: Relay Output Connector

## 5.8. Analog I/O Connections (Option)

Rectifiers which have the optional analog control will be equipped with the 138-0362-xx card and require customer supplied wiring. Depending on the analog board purchased it will be controlled by either a 4-20mA, 0-5V or 0-10V signal. See **Figure 5.10** and **Figure 5.11** below for connection diagrams.

See section **6.4 Analog Control (option)** for analog operation.

The following gives a description of the control and readback signals on the 20 pin socket block.

### VOLTAGE CONTROL (VC)

Control of the power supply output voltage can be achieved by connecting the appropriate signal to: Forward Voltage - pins 16 (+) and 15 (-), Reverse Voltage (if reversing unit) - pins 18 (+) and 17 (-).

### CURRENT CONTROL (CC)

Control of the power supply output current can be achieved by connecting the appropriate signal to: Forward Current - pins 12 (+) and 11 (-), Reverse Current (if reversing unit) - pins 14 (+) and 13 (-).

### VOLTAGE READBACK (VRB)

Monitoring of the power supply output voltage can be achieved by connecting the appropriate sensing circuitry to: Forward Voltage - pins 6 (+) and 5 (-), Reverse Voltage (if reversing unit) - pins 8 (+) and 7 (-).

### CURRENT READBACK (CRB)

Monitoring of the power supply output current can be achieved by connecting the appropriate sensing circuitry to: Forward Current - pins 2 (+) and 1 (-), Reverse Current (if reversing unit) - pins 4 (+) and 3 (-).

Pins 9 and 10 can be used for a DC COMMON connection.

Pin 19 and 20 can be used as a connection point for the cabling shields.

**NOTE:** To reduce the possibility of electrical noise interfering with the proper operation of the control system, use shielded twisted pair for all wiring between the analog controller and the power supply. Belden™ 8761 or equivalent cable type is recommended.

**NOTE:** The DC COM (pin 9 & 10) are used to connect the power supply's DC common to the controller's DC common. The shielding for the voltage & current control lines should be earth grounded at the controller and should be cut-off at the power supply. The shielding for the voltage & current readback lines should be earth grounded at the power supply (pin 19 & 20 - SHIELD) and cut-off at the controller. See diagrams below.

**NOTE:** When using 4-20mA control, the controller's input channels must be isolated from each other. It is recommended that isolated receivers (ex. OPTO 22 AD3T or equivalent) be used with the curr rb out and volt rb out transmitter channels. These transmitter channels are self powered.

The receiver inputs and transmitter outputs are ground isolated from the power supply's DC common and are isolated from earth ground as well. However, be aware that both input channels and both output channels of the AI board, do share a common signal ground. In other words, there is no isolation from channel to channel or receiver inputs to transmitter outputs except that provided by the differential inputs. A common ground signal from the Remote Analog Controller is required.

**NOTE:** Maximum loop resistance that can be in series between the (+) and (-) of the current or voltage readback signals is 400 Ohms

Units that require **both Fwd & Rev Current Control and Readback and Fwd & Rev Voltage Control and Readback** should be wired as shown in **Figure 5.10** below: (If current control is set as the regulation mode, then the voltage inputs are not required. If voltage control is set as the regulation mode, then the current inputs are not required. See NOTE and **Figure 5.11** below).

The Current and Voltage readback signals can be monitored at any time no matter what the regulation mode or control source is set to.

**NOTE:** The analog control card has control of the output current and voltage if it is enabled. To enable analog control it must be in one of the analog control modes. See section **6.1.7.3 SYS – System Key, 7>SetControlSource** for more information on the modes.

**NOTE:** When the 'Analog Control mode' is enabled the unit can only go to operate using the external operate input as described in section **5.6.1.2 Operate Input**. The other analog control modes can be put into operate either with the control panel or the host port.

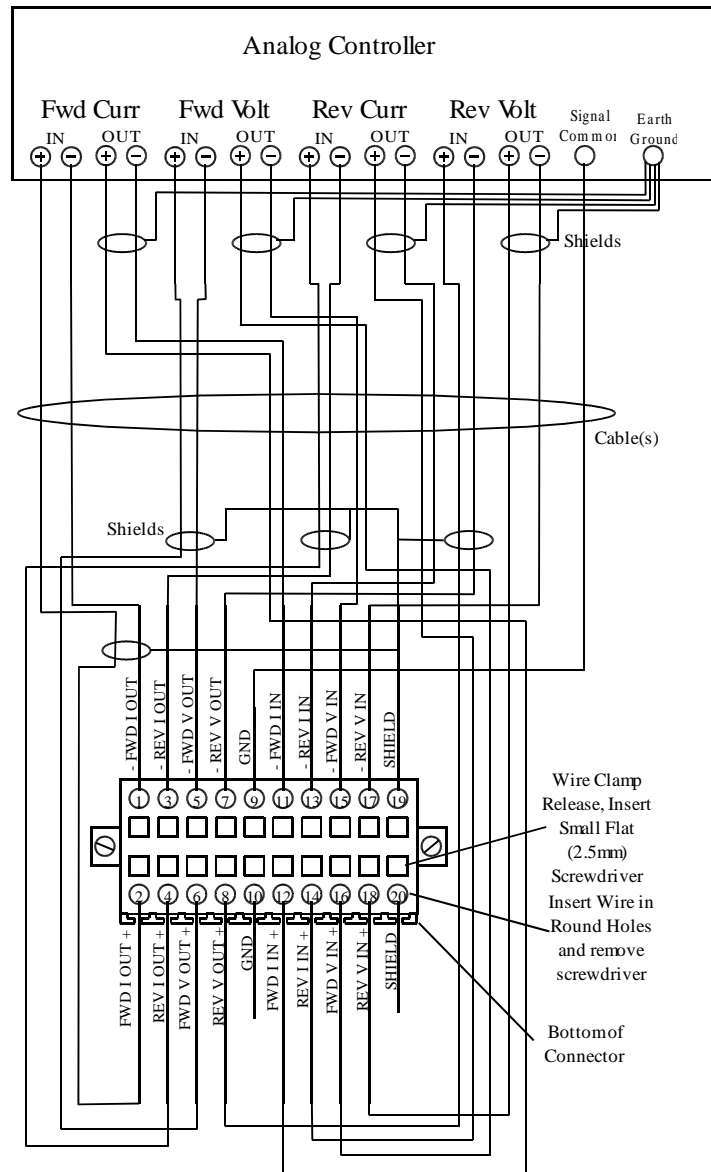

**Figure 5.10: Typical Analog Control Wiring (All Signals; Fwd & Rev Current and Fwd & Rev Voltage, Control and Reading)**

**NOTE:** If any of the analog channels are not being used they need to be jumpered as follows. **Figure 5.11** shows how to install jumpers if only the Forward Current channel is being used. This is required for proper operation of settings and readings.

Fwd Current channel is not used, jumper 1 to 11 and 2 to 12.  
 Rev Current channel is not used, jumper 3 to 13 and 4 to 14.  
 Fwd Voltage channel is not used, jumper 5 to 15 and 6 to 16.  
 Rev Voltage channel is not used, jumper 7 to 17 and 8 to 18.

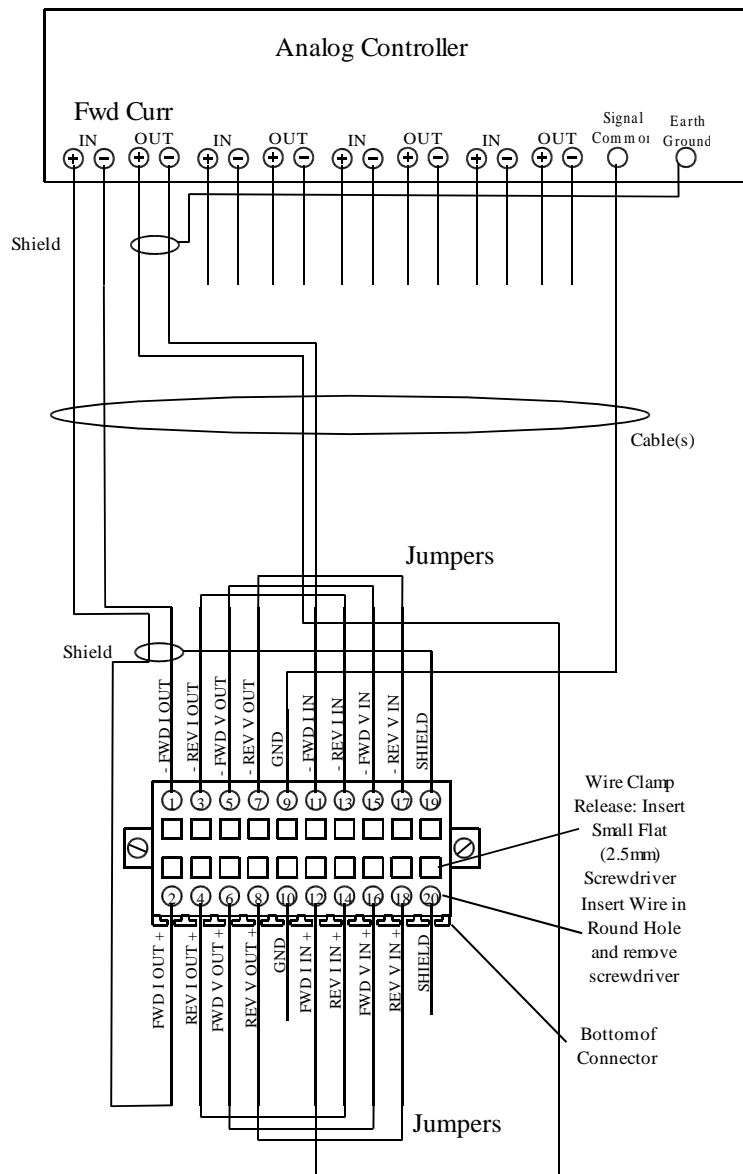

**Figure 5.11: Analog Connections - Fwd Current Only (with required jumpers in other channels)**



## 5.9. Master-Slave Connections – (Option)

The Master Slave option allows multiple power supplies to work in unison. There is one unit that is the Master and 1 to 9 Slave units that are slaved to the Master. The slaves use the same timing signals and cycle control durations as the master. Other settings, like current and voltage levels, can be different on the slave versus the master. See section 6.1.7.7 **M/S - Master/Slave Menu Key** and section 6.6.6 **MSV - Master-Slave Control** for more information.

### 5.9.1. Master-Slave Installation

The units will come set up as one Master and one or more Slaves. The serial number of the unit typically determines the order of the master and slave units. The lowest serial number is the master and the following serial numbers are slave1, slave2, etc. If there is just 1 slave, then the master and slave are connected together with one cable that has 15 pin male D Sub connectors on each end. If there is more than 1 slave then there is a special Y cable that goes from the master to the first slave and then possibly more Y cable(s) that go to the other slaves, and finally a normal cable that connects from the last Y cable to the last slave unit. Two connection diagrams are shown below.

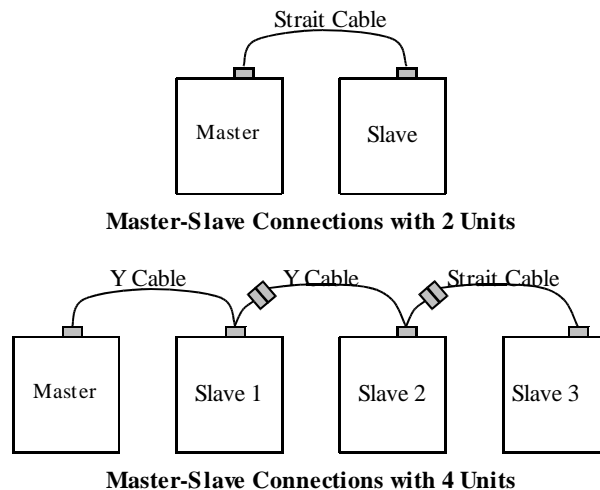

Figure 5.12: Connection Diagrams for Single and Multiple Slave Units

## 6. Controls and Operation

The MicroStar control panel is a user friendly power supply interface. It has many features that allow for complex plating processes but is also easy to set up for basic plating cycles.

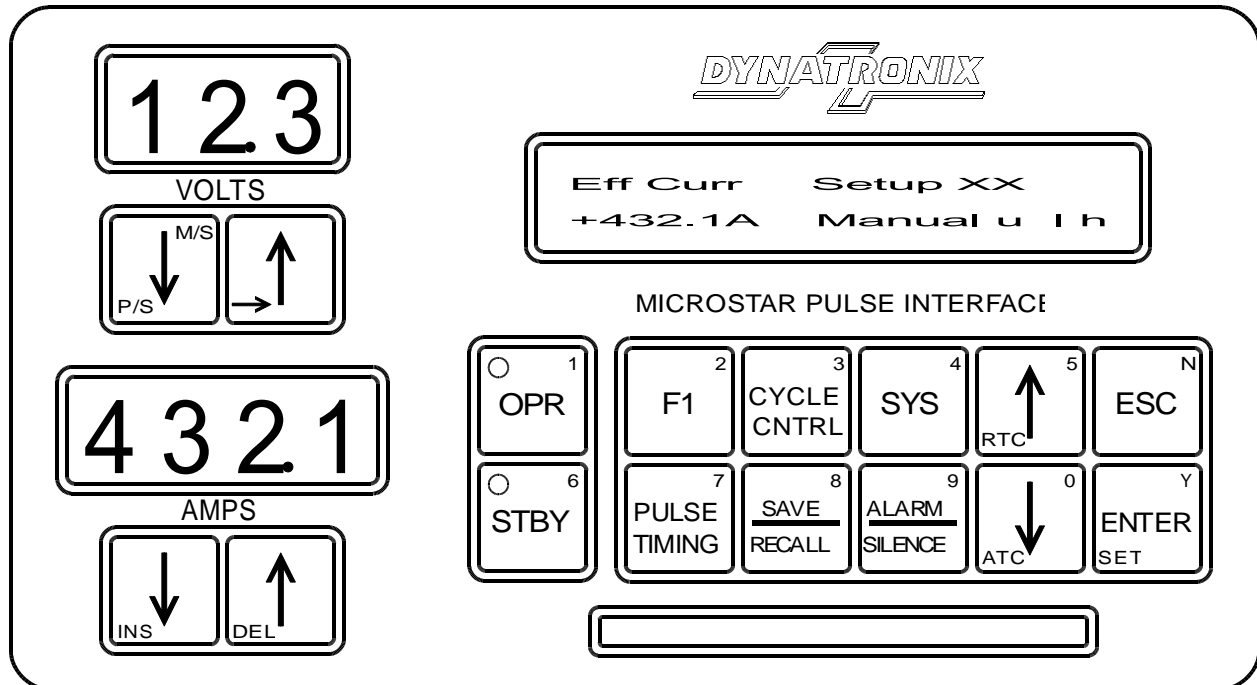

Figure 6.1: MicroStar Control Panel

The MicroStar controller is menu driven. When a menu key is pressed a list of options is displayed on the screen, two at a time. The **UP** and **DOWN Arrow** Keys are used to cycle through the menu and the **ENTER** key is used to select menu items. The **ESC** key will lead back to the Main Screen.

Some of the features are **PASSWORD** protected. The default password is 0000. The password is entered using the keys with numbers on them.

A summary of the different control panel features and their operation and use follows.

Read through Section **6.1 MicroStar Panel Controls** to get familiar with the User Interface Operation of the more advanced features is described in Section **6.2 Programming**.

The Host control capabilities are described in Section **6.3 Host Control** and **Appendix B Mach2 Host Protocol**.

Optional features that can be added to the unit are described in Section **6.6 Options**.

The optional Analog control of the output levels is discussed in Section **6.4 Analog Control (option)**

Section **6.8 Quick Start Guide** can be used for an overview of using the unit.

Use **Appendix A Menu Flow Chart** to view a flow chart of the screens and menus available.

## 6.1. MicroStar Panel Controls

The diagram below gives the locations in the manual that describe the key, display or meter.

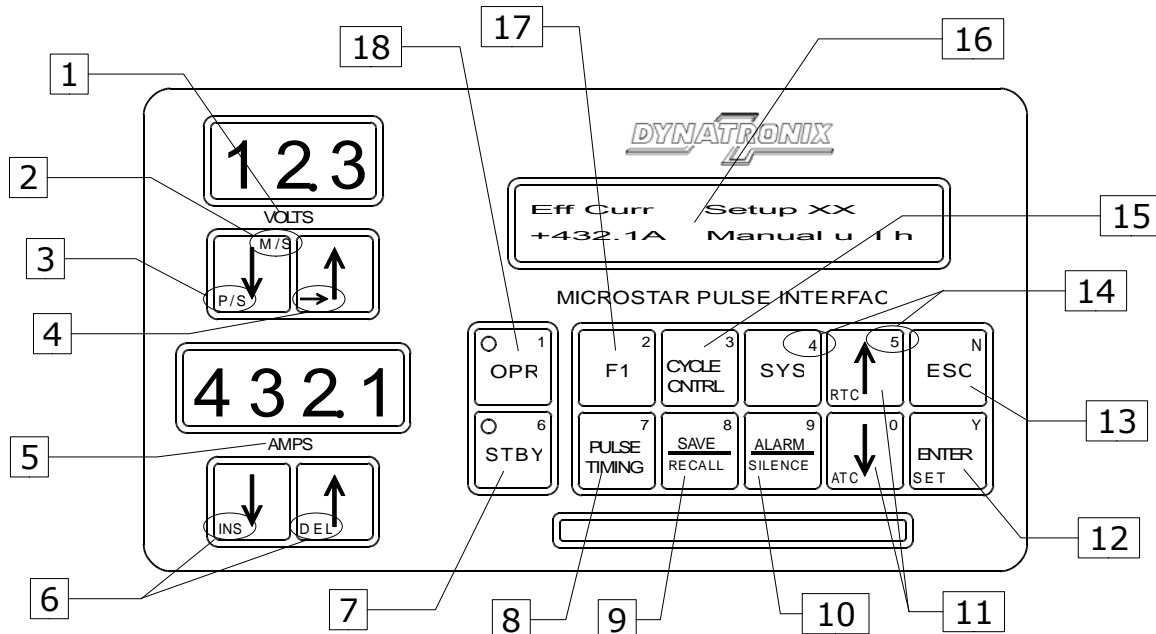
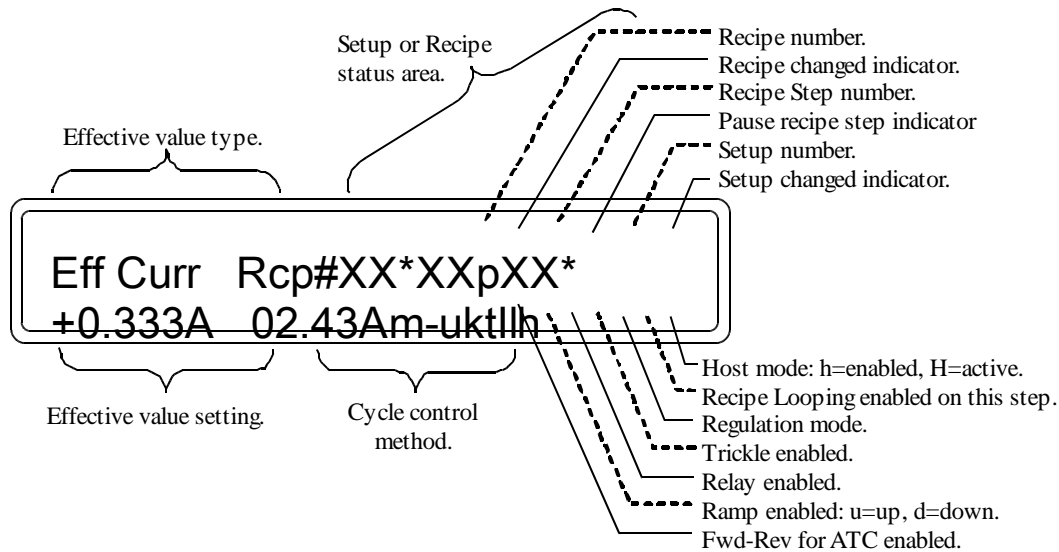

**Figure 6.2: Panel Item Description Location**

1. Page 39 - 6.1.2. VOLTS Meter and Controls
2. Page 39 - 6.1.3.3. M/S – Master/Slave Menu for Master-Slave option
3. Page 39 - 6.1.3.1. P/S – Pause/Step for Recipe option
4. Page 39 - 6.1.3.2. Right Arrow – Next Recipe Step for Recipe option
5. Page 41 - 6.1.4. AMPS Meter and Controls
6. Page 41 - 6.1.5.1. INS, DEL - for Recipe Option
7. Page 43 - 6.1.6.2. STBY – Standby Key
8. Page 56 - 6.1.7.4. PULSE TIMING – Pulse Timing Key
9. Page 58 - 6.1.7.5. SAVE / RECALL – Save and Recall Key
10. Page 59 - 6.1.7.6. ALARM / SILENCE – Alarm Key
11. Page 43 - 6.1.6.3. Arrow Keys and RTC and ATC Quick Set
12. Page 44 - 6.1.6.5. ENTER - Enter Key
13. Page 44 - 6.1.6.4. ESC - Escape Key
14. Page 44 - 6.1.6.6. Number Keys
15. Page 47 - 6.1.7.2. CYCLE CNTRL – Cycle Control Key
16. Page 36 - 6.1.1. Display
17. Page 45 - 6.1.7.1. F1 – Function Key 1
18. Page 43 - 6.1.6.1. OPR – Operate Key

### 6.1.1. Display

The Display shows settings, status and menus. **Figure 6.3:** below shows the Main screen of the display. This is the default screen and shows how the power supply is set up to run a job. Each area of the display has different information about the settings as shown below. **Figure 6.3:** shows the Main screen with optional Recipe mode which has all possible displayable items. If a Setup is active then the Rcp#... would be replaced with Setup XX as shown in **Figure 6.29** on page 62.



**Figure 6.3: Main Screen (in Recipe mode)**

There are up to 3 screens that display general status, settings and meter readings. They are cycled through by using the **ENTER** key. The Main screen, shown above, is the first, the Forward screen, shown below, is the second and, optionally, the Reverse screen is the third. The user must select the Forward or Reverse screens in order to set the voltage and current levels for forward or reverse respectively.

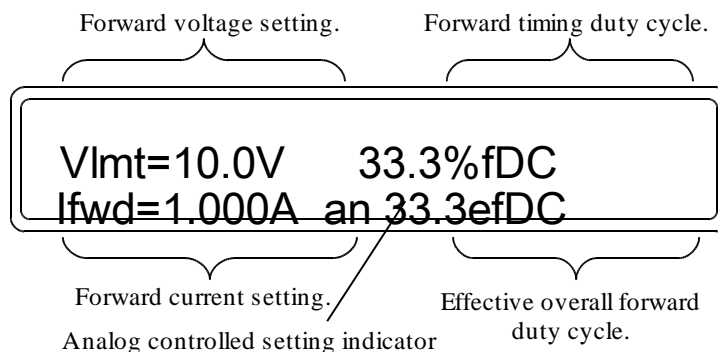

**Figure 6.4: Forward Settings Screen**

**Figure 6.4:** shows the settings for the forward voltage and current. The voltage and current settings are peak levels (On Time level). A small 'an' is shown beside one or both settings indicates that the setting is being controlled by the optional analog input(s). Depending on the regulation mode that is selected, one of the settings may show a limit value (i.e. Vlimt= for voltage regulation mode). This setting is the one that is not being regulated but will not allow the output to go beyond that level.

Also shown on this screen are the duty cycles of the pulsing settings. The fDC is the duty cycle of the settings during the forward time of the waveform. The efDC is the duty cycle of the forward time relative to the overall waveform including any reverse time. If there are no reverse settings then the two duty cycle values will be the same. If the settings are for DC output then both will be 100%.

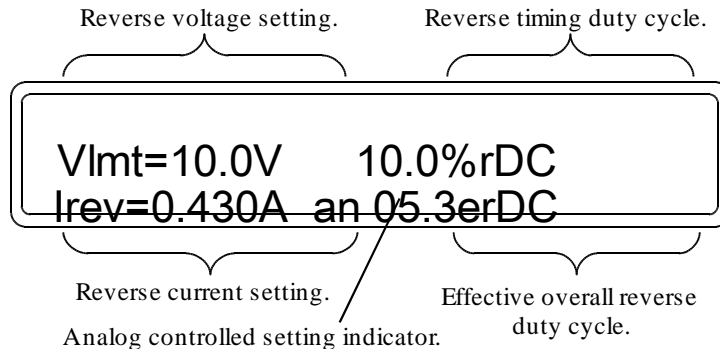

**Figure 6.5: Reverse Settings Screen**

**Figure 6.5:** shows the optional reverse voltage and current settings. It will only be displayed if the unit has reversing capability. The duty cycle information is similar to the forward screen but for the reverse settings.

### **6.1.1.1. Flashing Display**

A flashing display indicates that the unit has experienced a power failure while in operate. Press the **ALARM/SILENCE** key to see the message and clear the flashing display.

NOTE: This will only occur when the unit is in one of the power-fail recovery modes. These modes can be set using the information in the Section **6.1.7.3 SYS – System Key**, 1>StatusandMiscSettings 7>Set Power-FailMode - (UNIT) menu and more information is in Section **6.5 Power Fail Operation**.

The display also flashes when a timed cycle (ATC or RTC) is completed. Press **ESC** to clear the cycle done message.

### **6.1.1.2. Dual Range Output (option)**

The Dual Range Output option (DRO) changes the resolution of the settings depending on which range the unit is in. The range is determined by the current setting. For example if the unit was a DP20-10-30 the typical range change level would be 3 amps (10% of peak). Then when the current setting is at 3 amps or above the resolution would be XX.XX amps and when the setting is below 3 amps the resolution will be X.XXX amps. The AMPS meter will also change resolution. See also options section **6.6.7. DRO – Dual Range Output** on page 77.

### **6.1.1.3. Dual Level Control (DPD, DuPD & LFPD systems only)**

The Dual Level control system uses the Forward settings and Reverse settings as two different forward levels rather than having the reversing capability. When running Dual Level, note that the reverse current level (2nd fwd level) is not used for ATC cycle control. The 2<sup>nd</sup> level, "reverse", current is still accumulated in the main reverse totalizer however and can be accessed using the **CYCLE CNTRL** key or using the host protocol Readings command.

**6.1.1.4. Master-Slave Display Screens**

---

When the Master-Slave option is installed the screens are slightly different. The screens are shown below.

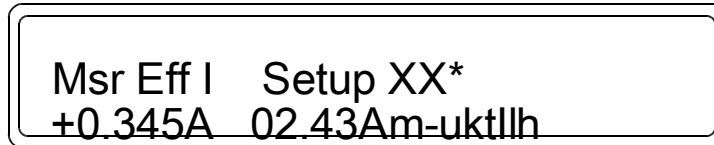

Figure 6.6: Main Screen for Master Unit



Figure 6.7: Main Screen for Slave Unit

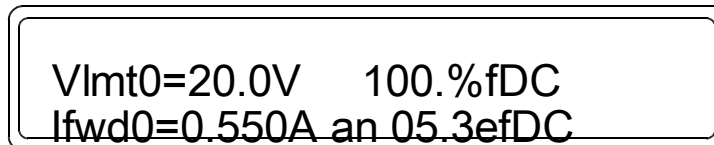

Figure 6.8: Settings Screen for Master Unit

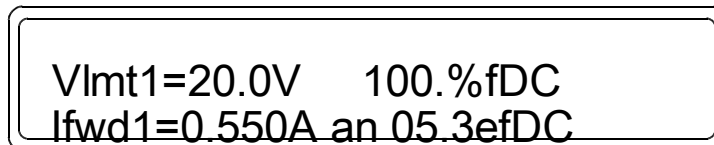

Figure 6.9: Settings Screen for Slave Unit

**6.1.1.5. Test Ref/Simulator Screens**

---

When the meter readback mode is set for Test Reference or Simulator mode then the main screen will look like the following for those modes. See 6.1.7.3 SYS – System Key 1>Status and MiscSettings 10>SetTest/SimRbMode- (UNIT).

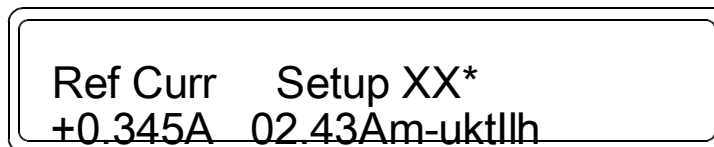

Figure 6.10: Main Screen for 'Test Reference' Readback Mode

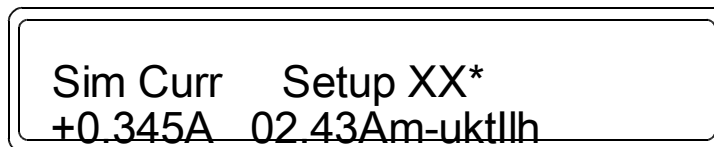
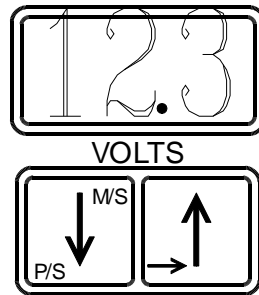

Figure 6.11: Main Screen for 'Simulator' Readback Mode

---

## 6.1.2. VOLTS Meter and Controls

---



**Figure 6.12: Volts Controls**

The VOLTS Meter displays the average output voltage when the unit is operating. The Volt Meter has an auto-range feature and will change between 0 to 9.99, 10.0 to 99.9 and 100 to 999 volt resolutions when at those levels (it will only change between 2 of those ranges depending on the unit's voltage rating). When the display is at the Main screen the Effective Average Voltage is displayed on the meter. When at the Forward Screen the Average Forward Voltage is displayed. Optionally when at the Reverse Screen the Average Reverse Voltage is displayed.

---

## 6.1.3. VOLTS Arrow Keys

---

The **VOLTS Arrow** keys adjust the voltage output level. These keys are only active when the Forward or Reverse settings screen is showing on the display (use the **SET (ENTER)** key to access them). The voltage level setting can be adjusted when the unit is in standby or while operating. The adjusted level is the peak, not the average, voltage on a pulsing unit.

The voltage cannot be adjusted when using current regulation mode.

### 6.1.3.1. P/S – Pause/Step for Recipe option

---

For the optional Recipe mode, the P/S key (Volts Down) is used to make a step pause when its cycle time is done. This feature is only used in the Recipe Edit mode. See section **6.2.2.1 Recipe Edit Mode - for Editing Recipes** for more information.

### 6.1.3.2. Right Arrow – Next Recipe Step for Recipe option

---

In the optional Recipe mode, the **Right Arrow** key (Volts Up) is used to cycle through the recipe steps shown on the Main screen when in standby. Each time the **Right Arrow** key is pressed the next Recipe step will be loaded and shown on the screen. The recipe step can then be edited. See section **6.2.2.1.1 Edit Recipe Keys for Recipe Edit Mode**.

This key can be used to manually step an operating recipe that has steps with MANUAL cycle control. See section **6.2.2.4 Running a Recipe**.

This key is also used in the SAVE/RECALL menus to cycle through screens of Setup and Recipe numbers. See section **6.2.1 Setups**.

### 6.1.3.3. M/S – Master/Slave Menu for Master-Slave option

---

Pressing this key when at the Main screen brings up the Master-Slave menu when the Master-Slave option is installed in the power supply. It is used to send settings from the master to the slave(s). See section **6.1.7.7** for more information.

#### **6.1.3.4. Flashing VOLTS Meter**

---

A flashing meter indicates that a voltage tolerance has been set and the reading is out of tolerance. This will only occur while the unit is operating. Tolerances are set in the **SYS**, 3>SetCurr & VoltTol- (SETUP) menu described in section **6.1.7.3 SYS – System Key**.



---

### 6.1.4. AMPS Meter and Controls

---

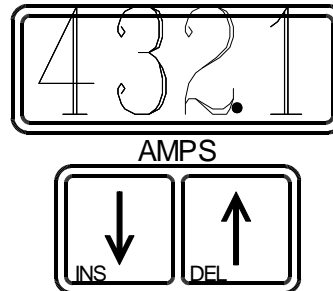

Figure 6.13: Amps Controls

Displays the Average output current when the unit is operating. When the display is at the Main screen the Effective Average Current is displayed. When at the Forward Screen the Average Forward Current is displayed. Optionally when the Reverse Screen is showing the Average Reverse Current is displayed.

The resolution of the meter is the same as the settings on the display, Amps or mAmps.

When the unit has the Dual Range Output (DRO) option the meter will change resolution depending on the what range the unit is in which is determined by the current setting.

NOTE: When the reading on the AMPS meter is reverse current (negative) the last digit will alternate between the digit value and the '-' (minus) sign.

#### 6.1.4.1. Dual Range Output (option)

---

Dual Range units have 2 current ranges for output and readbacks. When a current setting crosses the range cutoff current level the output range changes and the resolution on the meter also changes. The range change occurs automatically depending on the current setting.

Note that on reversing units the **current levels for both** the forward and reverse must be below the range change level in order for the range to change to low range.

---

### 6.1.5. AMPS Arrow Keys

---

The **AMPS Arrow** keys adjust the current output level. These keys are active when Forward or Reverse settings screen is showing on the display (use the **SET** (ENTER) key to access them). The current level setting can be adjusted when the unit is in standby or while operating. The adjusted level is the peak, not average, current on a pulsing unit. The current cannot be adjusted when using voltage regulation mode.

#### 6.1.5.1. INS, DEL - for Recipe Option

---

In the optional Recipe Edit mode the **INS** key (Amps Down) will insert a step at the current cursor location. The **DEL** key (Amps Up) will delete the step at the current cursor location. See section

### **6.1.5.2. Flashing AMPS Meter**

---

A flashing meter indicates that a current tolerance has been set and the reading is out of tolerance. This will only occur while the unit is operating. Tolerances are set in the SYS, 3>SetCurr & VoltTol- (SETUP) menu described in section **6.1.7.3 SYS – System Key**.

---

### 6.1.6. General Usage Keys

---

The following are descriptions of keys used for various actions while operating the power supply.

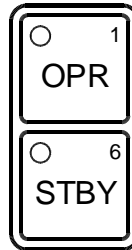

Figure 6.14: Operate and Standby Controls

#### 6.1.6.1. OPR – Operate Key

---

Enables the output and starts a timer based cycle if one is enabled. This key is disabled if the Analog Control option is enabled or the Host Control option is active.

The OPR Light on the key comes on when the unit is operating.

The OPR Light will flash when the unit is in the optional Trickle Mode.

#### 6.1.6.2. STBY – Standby Key

---

Disables the output and also allows an operating ATC or RTC cycle to be paused for some time. The output of the unit will be off when a cycle is paused unless the optional Trickle mode is enabled. A paused cycle can be restarted by pressing **OPR** or canceled by pressing **STBY**.

The **STBY** Light on the key is on when the unit is in standby and the output is off.

The **STBY** Light will flash when the unit is in Pause mode.

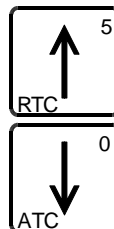

Figure 6.15: Arrow Keys and RTC & ATC Quick Set

#### 6.1.6.3. Arrow Keys and RTC and ATC Quick Set

---

These keys are used to adjust settings and to scroll through the menu options. If an ATC or RTC cycle is set and the Main screen is showing, pressing these keys will allow adjustment of the cycle duration.

The **RTC** (Up Arrow) key can also be used to quick-set a Real Time cycle if the Main screen shows Manualcycle mode.

The **ATC** (Down Arrow) key can be used to quick-set an Amp Time cycle if the Main screen shows Manualcycle mode.

If the Recipe option is installed, pressing the UP Arrow key during operate will show the

Recipe Looping status. The Looping values count down from the loop count setting to 1.

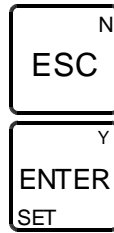

Figure 6.16: Escape Key and Enter & Set Levels Key

**6.1.6.4. ESC - Escape Key**

The **ESC** key takes the Display back to the Main screen. When in menus, pressing **ESC** will go back to the previous menu. Also gets out of settings that are being adjusted. NOTE: Settings will not be changed back to previous values if they have been adjusted. The **ESC** key is also used for a NO response to action confirmation questions.

In the optional Recipe Edit mode the **ESC** key is used to go to the start of the recipe. If pressed again when at the start of the recipe the **ESC** key will take the unit out of the Recipe Edit mode. When in the Loop Edit mode the **ESC** key will go back to step 1 settings if at a different step or exit the Loop setting mode if at step 1.

**6.1.6.5. ENTER - Enter Key**

The **ENTER** key is used to cycle through the Main screen, the Forward settings screen and optional Reverse settings screen.

Also, the **ENTER** key is used to accept values that have been adjusted. The **ENTER** key is also used as a YES response to action confirmation questions.

In the optional Recipe Edit mode the **ENTER** key is used to cycle through the recipe steps. In the Loop mode the **ENTER** key switches between the 2 loop settings.

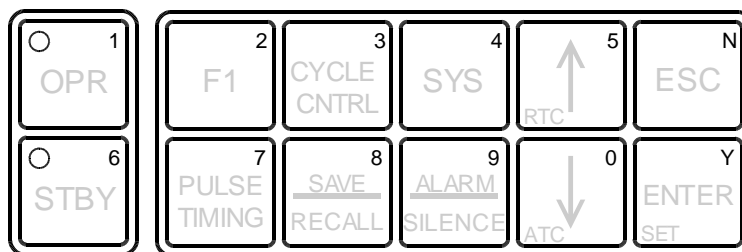

Figure 6.17: Number Keys

**6.1.6.6. Number Keys**

The number keys are used to enter Passwords, Setup Numbers and Recipe Steps and Numbers.

---

### 6.1.7. Menus

---

Menus are used to select various settings and functions. The screen displays 2 menu items at a time. The menu item on the first line with the small < pointer at the end of the line is the active menu item as shown in the screen image of the SYS menu, **Figure 6.18**.



**Figure 6.18: SYS Menu Screen**

Pressing the **DOWN Arrow** key will go down through the menu list (brings the larger numbers up to the first row). Pressing the **UP Arrow** key will go up through the menu list (smaller numbers to the first row). To select a given menu item use the **UP** and **DOWN Arrow** keys to get that item on the first line and then press the **ENTER** key.

Menus are available on the **F1, CYCLE CNTRL, SYS, PULSE TIMING, SAVE/RECALL, ALARM/SILENCE** and **M/S** keys. The following sections describe the menus.

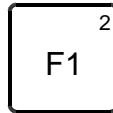

**Figure 6.19: Function Key 1**

#### 6.1.7.1. F1 – Function Key 1

---

Used to access some of the factory installed MicroStar Options as described below.

##### 1> RampMode(option)

Used to enable and disable ramping and to select either ramping Up or ramping Down

##### 2> RampTime(option)

Allows setting the duration of the ramp. When ramping Up, the ramp will start at the Ramp Offset value and ramp up to the current or voltage setting over the Ramp Time and then hold that setting until the cycle is done. When ramping Down, the ramp will start at the current or voltage setting and ramp down to the Ramp Offset value over the Ramp Time and then hold that level until the cycle is done. The ramp will control current in the current and crossover regulation modes and voltage in the voltage regulation mode.

##### 3> RampOffset(option)

Sets an offset value in % of setting and is the starting level for ramp up or the ending level for a ramp down. This setting is for current in the current and crossover regulation modes and voltage in the voltage regulation mode

**NOTE: Tolerance checking is not active while the output is ramping.**

#### 4> TrickleLevel(option)

Used to set a low current level for Trickle mode. The trickle level is set as a percentage of the current setting. This level must be greater than 0 for the trickle mode to be enabled using the menu item below.

When trickle mode is enabled it operates in the following fashion. When the unit is powered up the output is off. To start Trickle mode press the **OPR** key. The **OPR** Light will flash while the unit is in the trickle mode indicating that the output is active with a current level at the Trickle Level setting (in current regulation mode). A cycle can now be started from the trickle mode by pressing the **OPR** key again.

When a cycle ends, by pressing **STBY** when a Manual cycle is running or automatically when an ATC or RTC cycle is finished, the unit will set the output current to the trickle level. It will then read the voltage at the output and switch the unit to crossover regulation mode and set the voltage setting to the same value as the reading.

The trickle mode will remain on until the **OPR** key is pressed to start another cycle or the **STBY** key is pressed to shut off the output entirely. Use the **ESC** key at the end of an ATC or RTC cycle to clear the flashing display. Settings cannot be adjusted when the Trickle mode is active.

#### 5> TrickleEnable(option)

This item is used to enable and disable the Trickle mode. Press **ENTER** to turn the trickle mode on and off. There must be a Trickle Level set before the Trickle mode can be enabled. Press **ESC** once to get back to the F1 menu and again to get to the main screen.

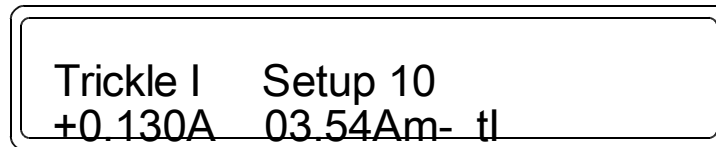

Figure 6.20: Trickle Mode Active Screen

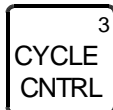

Figure 6.21: Cycle Control Key

### **6.1.7.2. CYCLE CNTL – Cycle Control Key**

---

Used to access the Cycle Control settings.

#### 1> RealTimeCycle(RTC)

This allows setting the duration of a Real Time Controlled cycle. Real Time cycles have a duration in hours, minutes or seconds. The resolution of the duration is set in the **6.1.7.3 SYS – System Key**, 4>SetResolutions (SETUP) 2>SetRealTimeResolmenu item. An RTC cycle will run for the preset time and then turn off automatically.

#### 2> AmpTimeCycle(ATC)

This allows setting the duration of an Amp Time Controlled cycle. Amp Time cycles have a duration in Amp-Hours or Amp-Minutes. The resolution of the duration is set in the **6.1.7.3 SYS – System Key**, 4>SetResolutions (SETUP) 3>SetAmpTimeResol. An ATC cycle will run for the preset amount of amp-time and then turn off automatically.

#### 3> RecipeCycle (option)

Recipe Cycle is used to set up a recipe that runs multiple setups in succession. See section **6.2.2 Recipes** below for more detailed information on recipes.

#### 4> RecipeLooping (option)

Recipe Looping is used to set up a recipe where steps can loop back to previous steps a preset number of times. See section **6.2.2.5 Looping Recipe Steps** below for more detailed information on recipe looping.

#### 5> ManualCycle

The Manual Cycle item is used to cancel an ATC, RTC or the recipe mode. The active recipe step will become the active setup when the recipe mode is canceled but the cycle time will change to Manual. The recipe mode can also be canceled by recalling a setup. Also an ATC or RTC cycle can be changed to Manual by adjusting the value to zero and pressing **ENTER**.

**6>RelayTripPoint (option)**

This is used to set the time between relay turn on points. After a cycle is started, the relay will turn on after the set amount of amp-time has been accumulated. The relay amp-time counter will be cleared and start accumulating amp-time again immediately. The relay will stay on for the duration set in menu item 7> below and then the relay will turn off. This will repeat for the duration of the cycle. Be sure to enter an amp-time setting that will run longer than the Relay On Time setting. The resolution of the Relay Trip Point setting is the same as the Totalizer resolution set in **6.1.7.3 SYS – System Key**, 4>SetResolutions (SETUP) 1>SetTotalizerResol.

**7>RelayOnTime (option)**

This is the duration that the relay will stay on after the Relay Trip Point amp-time, set in item 6> above, has been accumulated. The resolution is preset to XXX.X minutes (0.1 min (6 second) resolution) and cannot be changed. See Section **5.7 Relay Connections (pump control)** .

**8>ViewTotalizer**

This item allows the operator to view the main Totalizer. It will display the forward totalizer for a system that does not have reverse and both forward and reverse totalizers for systems that have reverse. This totalizer can be cleared using menu item 9> below.

**9>ClearTotalizer**

This menu item will clear the main totalizer. The correct password is required to clear the totalizer.

**10>SubtractReverseAmpTime**

This item is used to set the mode that an Amp Time Cycle counter uses to accumulate amp-time. When Subtract Reverses Amp Time is disabled the duration of an ATC is determined by the forward amp-time only. When it is enabled the amp-time accumulated for an ATC is the forward amp-time minus the reverse amp-time.



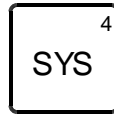

Figure 6.22: System Key

### 6.1.7.3. SYS – System Key

Used to access System Status and various System Settings.

**NOTE:** Some settings in the System menu relate to the Unit and others relate to a Setup. Unit settings are saved to Flash and are used until changed again in the SYS menu. Setup settings are saved in a setup and can change whenever a setup is recalled. This difference is indicated by **(UNIT)** or **(SETUP)** after the menu text.

#### 1> StatusandMiscSettings

This item is use to check various unit values and change unit settings including:

##### 1> ShowVersion& Model

Shows the firmware version that is running in the controller board and also the Model designation which includes the unit voltage and current ratings.

##### 2> ShowInstalledOptions

Displays the options that are installed the unit. See Section 6.6 for a list of available options.

##### 3> ShowSystemTimers

Shows the overall times for the unit which include the duration the unit has been powered On (hours), the duration the unit has been in Operate (hours) and the overall amp-time the unit has delivered (the sum of both forward and reverse amp-time) (Amp-Seconds, Amp-Minutes, Amp-Hours or kAmp-Hours (autoranging)).

##### 4> ExtOPRInputOptions- **(UNIT)**

Set how a remote operate switch will control the unit. The sub-menu selections are listed below.

##### 1> OPR w/Ext Inpt Closed

This is the default mode. The unit will operate when the switch is closed and go to standby or pause when the switch is opened. Use an on/off type switch.

##### 2> Set Opr/Stby 1 Push

This mode allows the cycle to be started with 1 push of a momentary type switch. When the cycle is done pressing the switch again will stop the flashing display, turn off the alarm if enabled and start a new cycle.

##### 3> Set Opr/Stby 2 Push

This mode will start a cycle with the first push of a momentary type switch. When the cycle is finished pressing the switch will only stop the flashing display and turn off any alarm. Pressing the switch a second time will start a new cycle.

**NOTE:** When a Manual cycle is set then 1 push will go to operate and

a second push put the unit in standby. If Trickle mode is set and a Manual cycle is set then the first press will put the unit into trickle and pressing it again will make the unit go to operate. Pressing the switch while operating will put the unit back into trickle mode. Use the STBY key to cancel the trickle mode.

When a timed cycle is running pressing the switch will put the cycle into the pause mode. A paused cycle can be restarted by pressing the switch once or canceled by pressing and holding the switch for about 2 seconds.

If Trickle mode is set and a timed cycle is set then the first press will put the unit into trickle and pressing it again will make the unit go to operate. Pressing the switch while the cycle is operating will put the unit into Pause-Trickle mode (paused cycle with trickle operating). A paused cycle can be restarted by pressing the switch once or canceled (standby) by pressing and holding the switch for about 2 seconds. Use the **STBY** key to cancel the trickle mode.

#### 5>RelayControlOptions- **(UNIT) (option)**

Controls what turns the optional relay output on and off. See section **5.7 Relay Connections (pump control)** on page **28**.

##### 1>ATC Controlled

This is the default mode. The relay is controlled by Amp-Time accumulation using the settings in the **CYCLE CNTRL** menu.

##### 2>On During Operate

The relay is on when the unit is operating. The relay will turn off when a cycle is paused or stopped and back on when restarted. The relay is off when the Trickle Mode is active.

##### 3>On During Alarm - **(UNIT)**

The relay turns on whenever an alarm sounds. Can be used for an external End Of Cycle indication using the EOC alarm.

#### 6>EditProtectis,Off- **(UNIT)**

This setting will not allow any Setups or Recipes to be edited when it is turned on. Setups or Recipes can only be recalled from memory when edit protection is on. To change the edit protection state press the **ENTER** key with this item showing on the top line. Enter the password to change the state.

A host can change settings when Edit Protect is On as long as one of the host control mode is enabled.

#### 7>SetPowerFailMode - **(UNIT)**

This menu is used to set how the unit will recover from a Power-Fail (PF) condition, either a brown-out where the voltage input level sags below a cutout point or a black-out where the voltage level goes so low that the unit has to reset the controller.

When one of the PF recovery modes is selected the unit will restore the operating parameters and state as described below.

1>Go to STBY after PF

This is the default mode. The power supply will always come up in Standby after a power-fail. If an ATC or RTC cycle was running, it will be canceled after a PF.

2>Go to Trickle after PF

When this mode is selected the unit will come up in the Trickle mode after a power-fail. The Trickle option must be installed and the Trickle mode enabled for this to work. This mode can also be used without Trickle as described in the NOTE below.

If the unit was in Standby at PF it will come up in Standby after the power is restored. If the unit was in Trickle state or Operate state it will return to the Trickle state after PF. If an ATC or RTC cycle was running, the unit will come up in the Pause state which will allow the cycle to be continued if the **OPR** key is pressed or canceled if the **STBY** key is pressed.

When the unit returns to the Trickle state the display will flash until the **ALARM/SILENCE** key is pressed. When the **ALARM/SILENCE** key is pressed the display will show PF, Alarm(s) Cleared indicating that there was a power-failure.

**CAUTION - When set for PF mode 2 if the unit is in Trickle state, then when the power is restored the unit will immediately return to the Trickle state. Anyone working with the unit needs to be informed when this mode is selected and that the output can become active automatically when power is restored.**

If the unit is in Trickle or Operate when the power switch is turned off, it will return to the Trickle state when the unit is powered up.

**NOTE:** this mode can be used without Trickle. It will work like the 'Go To Standby After PF' mode but with the added benefit that if an ATC or RTC cycle was running the unit will come up in the Pause state which will allow the cycle to be continued if the **OPR** key is pressed. It will also give the flashing display indication that a power-fail has occurred.

3>Go to State before PF

With this mode selected the unit will come up in the state that it was in before the power-fail. If the unit was in Standby it will come up in Standby after the PF. If the unit was in Trickle state or Operate state it will return to the Trickle or Operate state respectively.

When the unit was in Trickle it will return to the Trickle state immediately and the display will flash until the **ALARM/SILENCE** key is pressed. When the **ALARM/SILENCE** key is pressed the display will show PF, Alarm(s) Cleared indicating that there was a power-failure.

**CAUTION - in PF mode 3 if the unit is in Trickle state, then when the power is restored the unit will immediately return to the Trickle state. Anyone working with the unit needs to be informed when this mode is selected and that the output can become active automatically when power is restored.**

If the unit was in the Operate state at PF, when the power is restored it will sound the alarm for 20 seconds. The alarm can be silenced by pressing the **ALARM/SILENCE** key. During this time the display will show this screen.

PwrFailOPERATEin 20s

OPR=Operate,STBY=Cancel

This informs the operator that the unit will go into Operate after a count-down period of 20 seconds. During the count-down time the operator can choose to wait for the unit to come back on after the count-down, press the **OPR** key to resume the cycle right away, or press the **STBY** key to abort the cycle. After the count-down period the display will flash and when the **ALARM/SILENCE** key is pressed the display will show PF,Alarm(s)Clearedindicating that there was a power-failure.

If the unit was in Operate and an ATC or RTC cycle was running at PF, then when the power is restored the unit will restart the cycle where it left off.

Be aware that if the unit is in Trickle or Operate when the power switch is turned off, it will return to the Trickle or Operate state when the power switch is turned back on and give the power-fail indication described above.

#### 8> SetHostBaudRate- (UNIT)

Sets the desired baud rate for serial communications when using the RS485 port.

1> Set Baud 9600

Sets baud rate to 9600. This is the default baud rate.

2> Set Baud 19.2k

Sets baud rate to 19200.

3> Set Baud 38.4k

Sets baud rate to 38400.

4> Set Baud 57.6k

Sets baud rate to 57600.

#### 9> SetHostUnitAddr01 - (UNIT)

This item sets the Address that the Host uses to select this Unit when sending serial commands. Press **ENTER** to bring up the setting to adjust. Use the **UP and DOWN Arrow** keys to adjust the Address. Press **ENTER** to accept the address.

**NOTE: Make sure that not more than 1 unit has the same address when using a multi-drop RS485 communications bus.**

#### 10> SetTest/SimRbMode- (UNIT)

Controls where the meter readbacks come from.

### 1> Normal Readbacks

The meter readings come from the analog -to-digital converter that looks at the shunt for current and the output terminals for voltage.

### 2> Test Ref Readbacks

In this mode the meter readings still come from the analog-to-digital converter but the input to the converter is the reference signals that control the output levels. This is mainly used to test the circuitry to see if there is a problem. Note that the meter readings in this mode are not calibrated.

### 3> Simulator Readbacks

This item sets the meter readings to the Simulation mode. The meters will show a calculated reading value based on a default load resistance equal to the unit's Voltage Rating divided by the unit's Peak Current Rating. The resistance used for the simulation calculations can be changed using the User command described in the Mach2 Host Protocol in **Appendix B**.

## 2> SetRegulationMode- (SETUP)

Used to set the type of output regulation.

### 1> SetCurrentReg.Mode

Regulates current at the user set value and allows the voltage to vary up to the power supply's rated voltage. If the voltage reaches the supply's rating, the unit will automatically regulate voltage at the maximum value and the current will change to keep the voltage from going over rating.

### 2> SetCrossoverReg.Mode

Regulates both current and voltage so they do not go beyond the user set limits. In crossover regulation mode, either the voltage or the current will be at the setting and the other value will vary depending on the load.

### 3> SetVoltageReg.Mode

Regulates voltage at the user set value and allows the current to vary up to the power supply's current rating (peak or average depending on the pulsing settings for a pulsing unit) (up to peak rating when duty cycle is less than the ratio of average/peak current, up to average rating when the duty cycle is greater than the ratio of average/peak). If the current reaches the supply's rating, the unit will automatically regulate current at the maximum value and the voltage will change to keep the current from going over rating.

## 3> SetCurr & Volt Tol- (SETUP)

Sets the Tolerance window for the output current and voltage to stay within. A setting of zero disables the tolerance checking. The setting is a percentage of the current or voltage setting. When in Operate, if the output goes out of tolerance the meter for that given signal will flash. If the alarm is enabled for a current or voltage error the alarm will also sound. If the alarm is sounding, pressing the **ALARM** key will show which signal was out of tolerance.

<b>NOTE:</b> Tolerance checking is not active while the output is ramping.
--

## 4> SetResolutions- (SETUP)

The Resolution menu item is used to set the resolutions of the various parameters in the

system. Resolution can be set for:

1> SetTotalizerResol.

Sets the main totalizer and amp-time controlled relay accumulation.

2> SetRealTimeResol.

Set the resolution of real time cycles.

3> SetAmpTimeResol.

Set the resolution of amp time cycles

4> SetFwd/RevResolution

Sets the forward and reverse (if reverse is installed) timing resolution.

5> SetOn/Off Resolution

Sets the on time and off time pulsing resolution (if the unit has pulsing capability).

6> SetRampTimeResol.

Sets the resolution of the ramp time

7> SetCurrentRes.

Sets the current setting and meter resolution. The resolution can only be changed to a value less than the normal (default) resolution using this menu item. To change back to a higher resolution select the Normal setting and then select the new lower resolution.

5> CalibrateSets/Reads- **(UNIT)**

This menu item is used to calibrate the output and meters. Refer to Section 7 **Calibration** on page 93 of this manual for more information.

6> SetPassword- **(UNIT)**

Set Password allows the supervisor to set a password other than the default password of 0000. The password is required in order to set a new password. Use the number keys to enter the old and new passwords. The password is any four digit number.

7> SetControlSource- **(UNIT)**

This is used to select Panel or Host control modes or one of the Analog control modes if the optional Analog Interface is installed.

1> SetPanelCntrlMode

This menu item enables the Panel mode for use as a manual operator interface.

2> SetHostCntrlMode

This menu item enables the Host mode to allow a remote computer to control the unit. When the host is enabled the unit stays in panel control mode until the host sends a command at which point the host has control. When the host has control no settings can be changed using the control panel. The keys will only show the operating screens when pressed.

3> SetAnalogCntrlMode(**option**)

This item enables the analog control mode if an optional analog control card is installed. The analog control mode uses external signals to control the output levels of the unit. When this mode is enabled the unit can only go to operate using the external operate input as described in Section 26 **Operate Input** on page 26. , and Section 6.4. **Analog Control (option)**. When in analog control the following

operational modes are not allowed: RTC, ATC, Ramp, Trickle or Recipes. If the unit has pulsing and/or reversing capability the pulsing/reversing settings must be entered manually from the control panel.

4> SetPanelAnalogMode(**option**)

This mode operates just like panel control above but the output levels are set using the analog inputs. In this mode the unit can be operated from the front panel switches or the external operate input. All operational modes work in this mode; however the output level cannot be adjusted using the **VOLTS** and **AMPS** Arrow keys.

5> SetHostAnalogMode(**option**)

This menu item operates like the Host mode but the output levels are controlled by the analog inputs.



Figure 6.23: Pulse Timing Key

#### 6.1.7.4. PULSE TIMING – Pulse Timing Key

Used to access the settings that control the pulsing and the optional reversing of the output waveform. This key's menus are only available on units with pulsing and/or reversing features.

1> SetFwdOnTime

The pulse on time of the waveform.

2> SetFwdOffTime

The off time between pulses of the waveform.

3> SetForwardDuration (option for reversing units)

Sets the duration of the forward pulsing time if there is some reverse duration time set. Otherwise this can be any non-zero value.

4> SetReverseDuration (option for reversing units)

Sets the duration of the reverse pulsing time if there is some forward time set. If forward time is set to zero then the output will be reverse only and the reverse duration can be any non-zero value.

5> SetRevOnTime (option for pulse reversing units)

Used to set the pulse on time of the reverse part of the waveform. If there is no reverse duration set then this setting is ignored.

6> SetRevOffTime (option for pulse reversing units)

The pulse off time between reverse pulses for the reverse part of the waveform. If there is no reverse duration set then this setting is ignored.

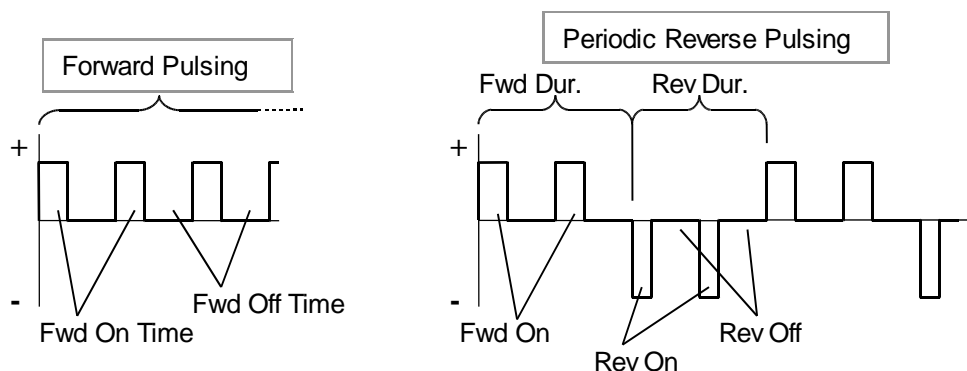

Figure 6.24: Pulse Timing Examples



When setting pulse timing values, the following rules apply for a Pulse Reversing unit.

- When running single direction, forward only or reverse only, the On and Off times rule the wave shape. The Direction time can be any non-zero value. For example, if the Forward Direction time is 1ms and the Forward On and Off times are 10ms then the waveform period would be 20ms for a frequency of 50Hz and a duty cycle of 50%.
- To run DC on a forward pulse only unit the On time can be any value and the Off time must be zero. For single direction DC on a Pulse Reverse unit or DC unit with reverse, the opposite Direction time must be zero.
- When running optional pulse reversing the Direction times rule. The On and Off times work within the given Direction time.

For example, if the timing was set the same as in the 1st rule above in both forward and reverse then the output would be on for 1ms forward and 1ms reverse for a waveform period of 2ms, a frequency of 500Hz and a duty cycle of 50% fwd/rev.

Another example would be  $F_{on}=2ms$ ,  $F_{off}=2ms$ ,  $Fwd=6ms$ ,  $Rev=4ms$ ,  $R_{on}=1ms$  and  $R_{off}=1ms$ . This would yield a waveform with 2 pulses of 2ms each in the forward direction for a 66.7% fDC  $((2+2) / 6)$  and 40% efDC  $((2+2) / (6+4))$ , and 2 pulses of 1ms each in the reverse direction for a 50% rDC  $((1+1) / 4)$  and 20% erDC  $((1+1) / (6+4))$ .

The Effective setting on the Main screen is calculated using: ('regulated fwd setting' x efDC - 'regulated rev setting' x erDC). Using the pulse settings in the second example above and current levels of 10A fwd and 5A rev the Eff value would be  $10A*40\% - 5A*20\% = 4A - 1A = 3A$ .

See **Appendix C Pulse Mathematics**, for more information about the calculations involved in pulse plating.

**6.1.7.4.2. Minimum Pulse On Time for Pulsing Power Supplies**

LFP (low frequency pulsing) power supplies have a minimum on time of 4 milliseconds when pulsing. The off time can be any value at the active On/Off time resolution. The LFP units can also be run with DC output by setting off time to zero. Other pulsing units typically have a minimum pulse timing of 0.06ms. The MicroStar controller will not allow timing shorter than the minimum to be set.

**6.1.7.4.3. Dual Level Timing ( DPD, DuPD & LFPD systems Only )**

Power supplies with the Dual Level control system use the Forward and Reverse timing settings to control the timing of the two different levels rather than having the reversing capability. The forward on time is one level and the reverse on time is the other level. The forward and reverse off times are always zero output level.

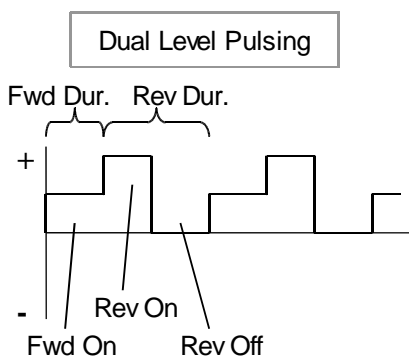

**Figure 6.25: Dual Level Pulsing Example**



Figure 6.26: Save/Recall Key

#### **6.1.7.5. SAVE / RECALL – Save and Recall Key**

Used to Save, Recall and Delete settings as Setups and Recipes if the recipe option is installed. A setup is a grouping of all the settings that can be set for a process step. A recipe is a grouping of setups where each step in the recipe is a setup.

- 1> SaveSetup
- 2> RecallSetup
- 3> DeleteSetup
- 4> SaveRecipe
- 5> RecallRecipe(option)
- 6> DeleteRecipe(option)

See sections **6.2.1.1 Saving Setups** and **6.2.2.3 Saving, Recalling and Deleting Recipes** for more information on saving and recalling.



Figure 6.27: Alarm / Alarm Silence Key

### 6.1.7.6. ALARM / SILENCE – Alarm Key

Used to enable and disable Alarms and to Silence alarms that are sounding. Press **ENTER** to enable or disable an alarm and **ESC** to exit the menu. The optional relay output can be activated by an alarm, See **6.1.7.3 SYS – System Key**, 1>StatusandMiscSettings5>RelayControl Options- (UNIT)(option) menu item.

#### 1>EndOfCycleAlarm

The alarm will sound at the end of an ATC or RTC cycle when this alarm is enabled. The alarm output on the digital I/O connector will also go active when the alarm is sounding.

#### 2>CurrentToleranceErrorAlarm

When this alarm is enabled the alarm will sound when the current at the output is outside the tolerance setting. Note that a tolerance setting of 0 disables tolerance checking.

#### 3>VoltageToleranceErrorAlarm

When this alarm is enabled the alarm will sound when the voltage at the output is outside the tolerance setting. Note that a tolerance setting of 0 disables tolerance checking.

#### 4>RelayOutputOnAlarm(option)

Enabling this alarm will cause the alarm to sound while the ATC Relay Output is on. The relay output is generally used for a pump (that adds chemicals to the bath) and is controlled by the relay settings in **6.1.7.2. CYCLE CNTL – Cycle Control Key** menu . The relay output can be used for other things as described in section **6.1.7.3 SYS – System Key**, 5>RelayControlOptions- (UNIT)(option) menu item.

If an alarm is sounding when the **ALARM/SILENCE** key is pressed the Display will show what type of alarm caused the problem and silence the alarm (if the alarm condition persists, the alarm will sound again when the key is released, press **STBY** and determine the cause of the alarm). The following is a list of alarm codes that can show.

EOC- End-of-Cycle alarm - activated when the end-of-cycle alarm is enabled and an ATC or RTC cycle finishes.

CERR- Current out of tolerance error.

VERR- Voltage out of tolerance error.

HS\_OT- Heat Sink Over Temperature - the internal heat sink is overheating, probably due to reduced air flow, check that the fan(s) are operating and vents are free of obstructions

BB\_OT- Bus-Bar Over Temperature - one or both of the output bus-bars is overheating, probably due to loose connections or cable crimps.

RELAY- Relay On alarm - whenever the relay comes on during an ATC controlled Relay cycle and the relay alarm is enabled the alarm will come on. Pressing the **ALARM/SILENCE** key will silence the alarm and show this message code.

PF- Power Fail - indicates that the power failed while the unit was operating. This will only

occur if one of the Power-Fail modes is set (see section **6.1.7.3 SYS – System Key**)

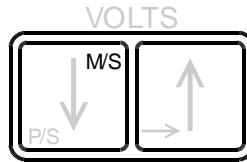

Figure 6.28: Master-Slave Key

#### **6.1.7.7. M/S - Master/Slave Menu Key (Volts Down key) - (Option)**

The **M/S** key is used to access the Master-Slave menu for sending settings, Setups or Recipes, to the slave units. This menu is only accessible from the Main Screen (Eff) and only in Standby. The menu items are listed below with their function.

##### 1> SendAll M/S Settings

This menu item is used to send all settings to the slave(s). If a Setup is loaded then pressing **ENTER** with this menu item showing will send all settings of the Setup to the slave(s). The settings include: output levels, timing, regulation mode, tolerances, resolutions, alarm settings, cycle settings, and for optional features: ramp settings, relay settings, and trickle settings.

If the unit has the Recipe option and there is a Recipe loaded with multiple steps and setups, then when **ENTER** is pressed with this menu item showing, the Recipe settings will be sent along with all settings from each of the Setups in the Recipe.

##### 2> SendAll But Levels

This menu item is used to send all settings except the Output Levels (voltage and current) to the slave(s). This is used when various settings are changed on the master and those changes need to be sent to the slave(s) but the output levels settings on the slave should stay the same. Using this menu item the slaves will load all settings except for the output levels.

##### 3> SendTimingOnly

This menu item is used to send only the timing values to the slave(s). It would be used when a timing change is made on the master and the other slave settings should stay the same. The slaves require the proper timing values in order for the meter readings to be accurate.

**NOTE:** If Host control is being used for Master-Slave the settings to run the Slave are sent directly to the Slave. Make sure the Timing is the same for both the Master and the Slave in order to get the proper readbacks from the Slave.

## 6.2. Programming

### 6.2.1. Setups

Setups are used to save a set of settings for recall when needed. A Setup can save settings for a Manual cycle, RTC cycle or an ATC cycle. All the settings that control the power supply for any given cycle are saved to non volatile memory, these include timing settings, regulation mode, tolerances, all resolution settings, ramp control, amp-time relay control and trickle mode (Unit settings are not saved to a setup). The Setups that are saved can be recalled when needed for a particular job. They can also be used as steps in the Recipe option.

The status of the setup is shown in the upper right corner of the main screen as shown in **Figure 6.29**. If the setup status shows SetupXX\*, the XX means that the setup has not been saved to permanent memory yet. The \* indicates that the setup has changed since the last save. The second line shows the settings for this particular setup.

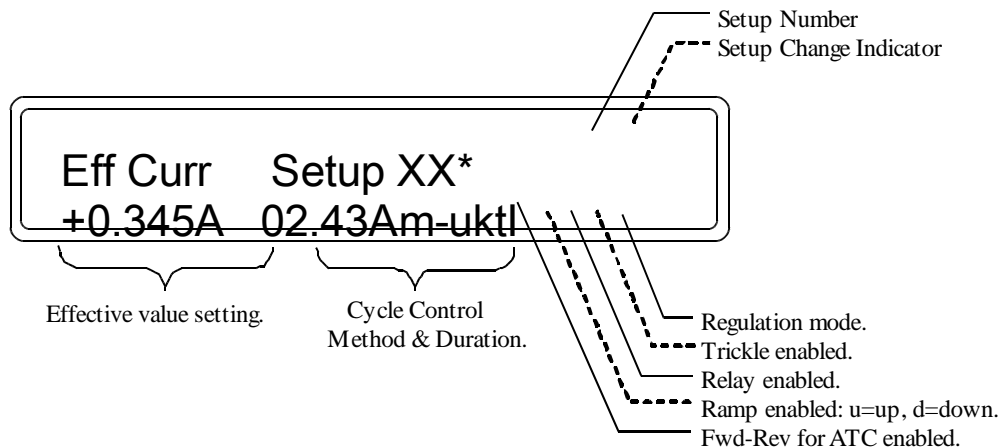

**Figure 6.29: Main Screen Indicating the Setup Parameters**

### 6.2.1.1. Saving Setups

---

To save a Setup, change all the settings to the desired values. Then press the **SAVE / RECALL** key. Select 1>SaveSetup from the menu. The following screen will appear:

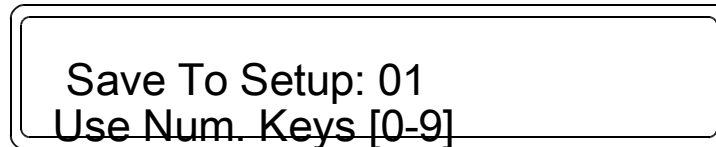

Figure 6.30: Setup Save Screen, Initial View

After a short time the second line of the screen will change showing the setups that are used and unused as shown on the following screen. An `e` after the number shows that the setup location is empty. A blank space shows that it is used. The --> arrow at the end of the line indicates that there are more setup locations available. The **Right Arrow** key (VOLTS Up) can be used to cycle through screens of setups with 5 setups shown per screen.

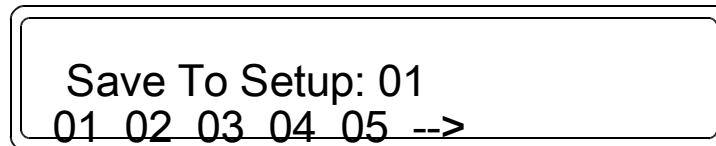

Figure 6.31: Setup Save Screen with Used List

Enter the desired 2 digit setup number using the number keys. The flashing cursor shows which digit will be entered. Press the **ENTER** key to save the setup to flash memory. If there is already a setup saved at that location the unit will ask for confirmation as to whether or not the setup should be overwritten. Pressing **ENTER** again will save the setup and overwrite the old one. Pressing **ESC** will not save the setup and return to the **SAVE / RECALL** menu where the setup can be saved to a different location.

### 6.2.1.2. Recalling Setups

---

To recall a setup, press the **SAVE / RECALL** key. Select 2>RecallSetup from the menu. Enter the desired setup number using the number keys as described in Saving Setups above. Press **ENTER** to recall the setup from flash into active memory. A confirmation screen will appear asking whether or not the currently active settings should be overwritten by this setup being recalled.

### 6.2.1.3. Deleting Setups

---

To delete a setup, press the **SAVE / RECALL** key. Select 3>DeleteSetup from the menu. Enter the desired setup number using the number keys as described in Saving Setups above. Press **ENTER** to delete the setup from flash memory. A confirmation screen will appear asking whether or not the selected setup should be deleted.

---

## 6.2.2. Recipes

---

Recipes are an optional feature that allows setups to be linked together to perform more complex plating cycles. A recipe has up to 8 steps that can be loaded with setups. The steps can be any setup that has been saved. The setups can be in any order and any setup can be repeated any number of times in the recipe up to the maximum number of steps allowed in the recipe.

Recipes use the setups in memory. This means that if a setup is part of a recipe and that setup is changed and saved, the function of the recipe will also change.

**CAUTION: Care must be taken to prevent undesired changes to recipes when editing and saving setups.**

There are several steps in creating a working recipe. A basic recipe with the desired number of steps, with setup numbers entered for each step, must be created. The setups in a recipe can be created and saved before or after a recipe is created. If the setups were not edited and saved before creating the recipe, then they will need to be edited and saved before the recipe can be run.

### 6.2.2.1. Recipe Edit Mode - for Editing Recipes

---

To create a recipe, press **CYCLE CNTRL** and select 3>RecipeCycle (option) menu item. This puts the unit into the Recipe Edit mode and a screen will appear with a blank recipe ready for editing as shown in **Figure 6.32** below. The S01 at the top left of the display stands for Step1 of the recipe. The flashing cursor below the S01 is waiting for the entry of a setup number.

S01 Enter Recipe Setups  
Use Number Keys

**Figure 6.32: Recipe Edit Screen, Initial View**

Enter the desired setup numbers for the recipe using the Number Keys (must be 2 digits for each setup). The step numbers will automatically increment as setup numbers are entered as shown in **Figure 6.33** below. The --> arrow after the last step number shows that there are more recipe steps available. If there are 5 or more setups entered the **Right Arrow** key (VOLTS Up) can be used to cycle through screens of steps with up to 5 steps shown per screen. The --> arrow will go away when there are no more steps available.

S01 S02 S03 S04 S05 -->  
01 02 05 03

**Figure 6.33: Recipe Edit Screen with Setup Numbers**



### 6.2.2.1.1. Edit Recipe Keys for Recipe Edit Mode

There are a number of keys used to edit and modify a recipe when in the Recipe Edit mode. These are listed below.

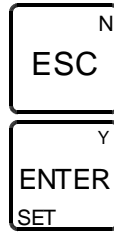
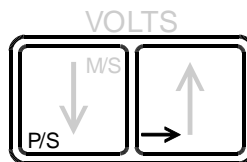

**Figure 6.34: Escape Key and Enter Key**

**ESC Key** - In the Recipe Edit mode the **ESC** key is used to go to the start of the recipe. If pressed again when at the start of the recipe the **ESC** key will take the unit out of the Recipe Edit mode and into Recipe mode (unless no setups were entered).

**Clear Recipe** - A recipe can be cleared out (no steps) by pressing and holding the **ESC** key for about 1 second. A confirmation screen will appear asking whether or not to clear the recipe data. Press **ENTER** to clear the recipe data (no steps) or **ESC** to keep the recipe data. This can be used to start a new recipe.

**ENTER Key** - In the Recipe Edit mode the **ENTER** key is used to cycle through the recipe steps. If there are more than 5 steps and the cursor is at the last step on a screen then the next screen will show when the **ENTER** key is pressed.



**Figure 6.35: Pause Recipe Step Key and Right Arrow Key**

**P/S - Pause / Step Key** - In the Recipe Edit mode the **P/S** key (VOLTS Down) is used to change the pause state of the recipe step that the flashing cursor is under. Pressing the **P/S** key will change the step from S to P and back again, i.e. S02 to P02 to S02.

Use the **ENTER** key to position the cursor under the step to be paused. Press the **P/S** key to change the pause state of that step.

When the step shows a P, the step will run and then pause the recipe when that step's cycle is done. The pause function can be used when a part has to be moved or rotated during a recipe.

**RIGHT ARROW Key** - If there are 5 or more setups entered the **Right Arrow** key (VOLTS Up) can be used to cycle through screens of setups with 5 setups shown per screen. The --> arrow will go away when there are no more steps available.

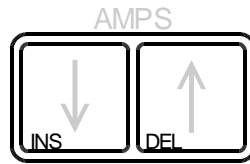
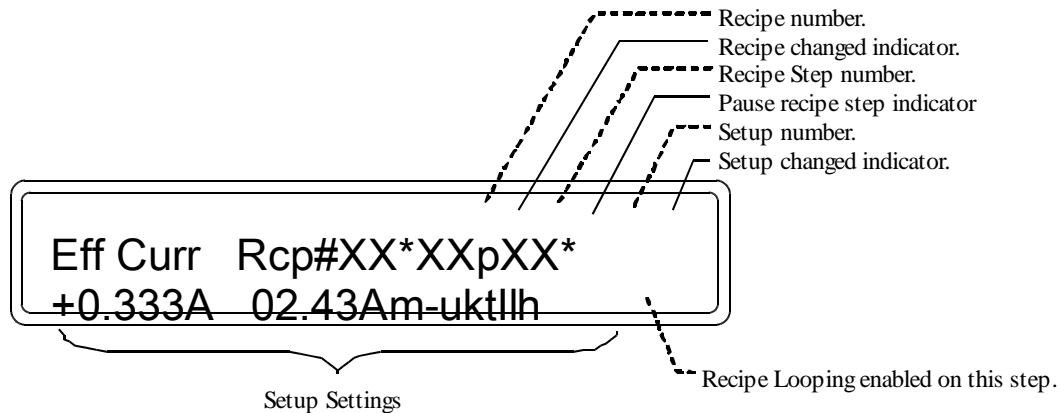

**Figure 6.36: Insert and Delete Keys**

**INS and DEL** - Insert and Delete Keys - In the Recipe Edit mode the **INS** key (AMPS Up) will insert a step at the current cursor location. The **DEL** key (AMPS Down) will delete the step at the current cursor location.

### 6.2.2.2. Recipe Mode

When finished entering steps press the **ESC** key once to get to the start of the recipe and again to exit the Recipe Edit mode. Press **ESC** to get back to the Main screen if it is not shown. The Main screen will now show the recipe status in the upper right corner as shown in **Figure 6.37** below. This is the Recipe mode where the recipe can be run or the setups in the recipe edited. The Recipe mode is also activated whenever a saved recipe is recalled from memory.



**Figure 6.37: Main Screen Indicating Recipe Parameters**

When the screen shows Rcp#XX, the XX indicates that the recipe does not have a number yet because it has not been saved. If the recipe status shows Rcp#XX\*, the \* indicates that the recipe has changed but is not saved. Also a \* behind the Setup number means the active step's setup has changed and is not saved. A recipe cannot be run if a setup is unsaved.

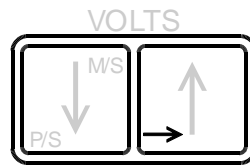

**Figure 6.38: Right Arrow Key**

**RIGHT ARROW Key** - When in the Recipe mode (Rcp# is shown on the main screen) the **Right Arrow** key (VOLTS Up), shown in **Figure 6.38** above, is used to cycle through the recipe steps shown on the main screen. Each time the **Right Arrow** key is pressed the next Recipe step will be loaded.

#### **6.2.2.2.1. Editing Setups in Recipe Mode**

The setups within the recipe can be edited when in the Recipe mode if desired. Use the **Right Arrow** key (VOLTS Up), as shown in **Figure 6.38** above, to cycle through the steps. If the current step has changed, the unit will not allow the next step to be displayed unless the current setup is saved or the edits canceled. A confirmation screen will appear showing that the setup has changed and asking if it should be saved. Pressing **ENTER** will save the setup changes and then display the next step. Pressing **ESC** will display the next step and the setup changes will be lost.

#### **6.2.2.2.2. Canceling Recipe Mode**

The Recipe mode can be canceled by selecting **CYCLE CNTRL**, 5>ManualCycle menu item. The active recipe step will become the active setup when the recipe mode is canceled but the cycle time will change to Manual

The recipe mode can also be canceled by recalling a saved setup.

#### **6.2.2.3. Saving, Recalling and Deleting Recipes**

Recipes are Saved, Recalled and Deleted just like the Setups description at **6.2.1 Setups** above by using the following menu items on the **SAVE/RECALL** key.

- 1>SaveRecipe
- 2>RecallRecipe
- 3>DeleteRecipe

**NOTE:** If the power supply is turned off or power is lost any changes to the active recipe step's Setup will be lost due to recalling the saved values from flash at power-up (the saved setups will not be lost). Be sure to save any Setup changes promptly.

A recipe that has not been saved can be run. A changed recipe is saved to the power-fail flash area when power is lost and recalled at power-up with the same changes and the \* change indicator showing.

#### **6.2.2.4. Running a Recipe**

If a Rcp# is showing on the display then the unit is in the Recipe mode. To run the recipe, press the **OPR** key. The unit will check the setups in the recipe to see if they are valid before operating. If one or more are not valid, a screen will appear to allow the first invalid setup to be edited and saved. If the setups are valid the unit will load the first step's setup

and run it. When that setup is finished the next step's setup will load and run. This will continue until all steps have been run and the unit goes to standby and flashes the end of cycle display message.

If any of the steps has the pause at the end of step enabled the unit will go into the pause state. The next step in the recipe can be started by pressing the **OPR** key.

**NOTE:** In order for a recipe to run automatically, setups within a recipe must have either Real Time or Amp Time cycle control.

A recipe can be stepped manually by setting the Setup to Manualcontrol and using the **Right Arrow** key (VOLTS Up) to change to the next step when desired while operating.

### 6.2.2.5. Looping Recipe Steps

The Looping function allows a step or series of steps to be repeated a preset number of times. The Looping function only works with the Recipe option. The loops can be nested up to 8 levels (one loop for each of the 8 available recipe steps). Up to 8 steps can be repeated in any given loop (only the 8th step can repeat all 8 steps). Each loop can run up to 9999 times.

#### 6.2.2.5.1. Editing Loops

Loop Edit mode is entered by selecting the **CYCLE CNTRL**, 4>RecipeLooping (option) menu item. A recipe needs to be active for this function to work. The editing screen looks like the one shown below.

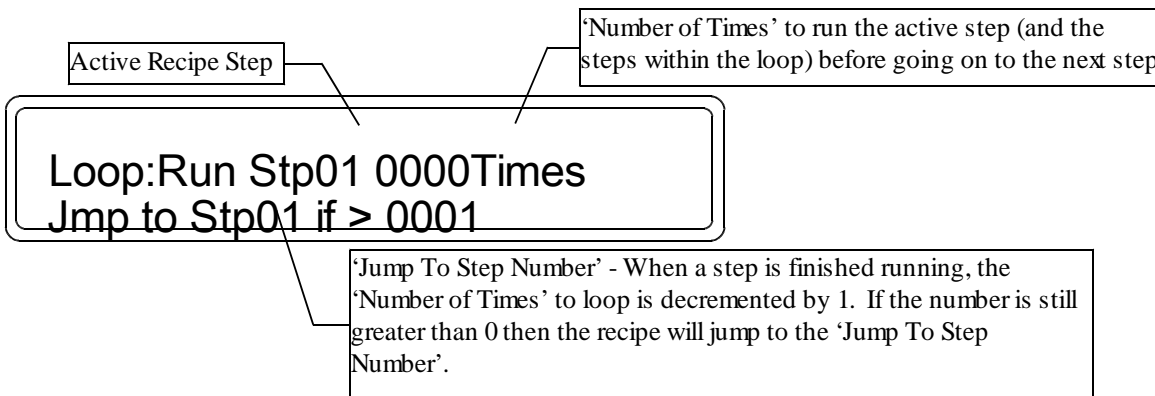

**Figure 6.39: Recipe Looping Edit Screen**

Use the **Right Arrow** key (VOLTS Up) to cycle through the steps in the recipe so that Number Of Times and Jump To Step for each step can be set.

Use the **ENTER** key to switch between the '0001Times' (Number Of Times) to repeat this step and the 'JmpToStp01 (Jump To Step Number) selections.

Use the **ESC** key to return to the first step. If the loop display is at the first step then pressing the **ESC** key will take the unit out of Loop Edit mode.

To enter the Number Of Times use the **UP** and **DOWN** Arrow keys. Press the **ENTER** key if the cursor is not blinking next to the Number Of Times. The minimum number of times is 1, which runs the active step only once and continues with the following step. Setting this value to 2 will run this step and then decrement the Number Of Times to 1 and then go to the Jump To Step and run that step and any step between that step and this active step. It will then run this step again and decrement the Number Of Times to 0 and go on to the following step. Any number up to 9999 can be entered.

To enter the Jump To Step Number use the **NUMBER** keys. Press the **ENTER** key if the cursor is not blinking next to the Jump To Step number. Press the number keys corresponding to the step number in the recipe that the recipe should jump to after this step is complete. Only numbers 1 to 8 can be entered. The editor will not allow entry of a number larger than the current active step number (can only jump to previous steps).

**Clear All Loop Values** - Holding down the **ESC** key for about 1 second when in the Loop Edit mode will bring up a confirmation screen asking whether to clear the loop data or not. Press **ENTER** to clear the loop data or **ESC** to keep the loop data. Clearing the looping values sets them to the defaults (Number of Times = 0001, Jump to Step = 01 for no looping). These values are also cleared when a new recipe is started or the Recipe mode is canceled.

The diagrams below show how looping recipes work and what settings to enter in the looping edit screen.

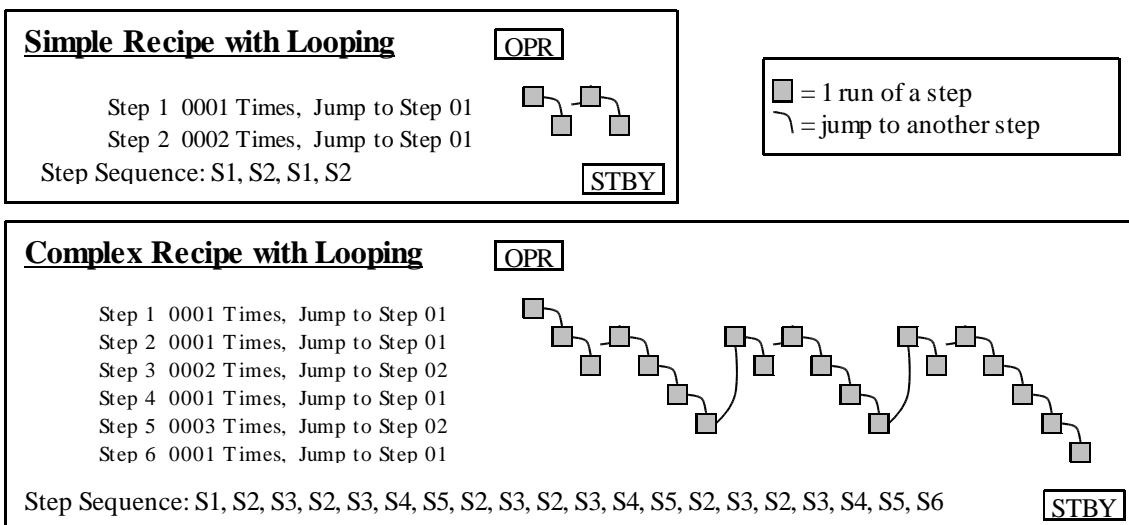

Just a note for curiosities sake: If 160 Times was put into 8 steps and they all jumped to step 1 and each setup had an RTC of only 1 second, it would take close to 13.6 billion years for the recipe to finish or about the theoretical age of the universe.

**Figure 6.40: Recipe Looping Examples**

---

## 6.3. Host Control

---

The MicroStar Series rectifier can be controlled by a host (Computer, PLC, etc) using one of the host ports and the ASCII host protocol. The host port can be used to monitor the settings or read back values at any time. The host port can only modify settings if the unit is in Host control mode or Host-Analog control mode. These modes are selected in the **6.1.7.3. SYS – System Key, 7>SetControlSource** (UNIT) menu or by using the User Settings host protocol command described in **Appendix B Mach2 Host Protocol**.

---

### 6.3.1. Host Ports

---

The unit comes standard with an RS485 host port and a USB host/service port.

**RS485** - The RS485 port is an industrial, multi-drop, control port used for longer distances. Each unit on a multi-drop bus requires a unique unit address so that it can be individually addressed. See **Appendix B.4 Communications Settings – RS485** for more information on the RS485 port.

**USB** - The USB port is a single connection port used for short distances to the host. The host requires a USB port and a USB driver. The USB driver is typically set up as a Virtual Com Port driver. See **Appendix B.5 Communications Settings – USB** for more information on the USB driver. This port is also used for upgrading the firmware in the unit.

NOTE: The host port Baud Rate and Unit ID are dumped out the USB port at power-up along with the firmware version and unit information at a baud rate of 115200.
--

---

### 6.3.2. Host Port Connections

---

The connector pin-out for the RS485 port can be found in the Installation section, **5.5.1 RS485 Host Port Connections** on page 24. The USB port uses a standard Type B connection.

---

### 6.3.3. Host Port Communications Settings

---

The host port settings include a Baud Rate (9600, 19200, 38400, 57600, 115200) and Unit ID (1 to 99). These setting can be set from the control panel using the **6.1.7.3. SYS – System Key, 1>StatusandMiscSettings** menu items, **8>SetHostBaudRate** (UNIT) and **9>SetHost UnitAddr01** - (UNIT) or via the host port with the User Settings command described in **Appendix B**.

---

### 6.3.4. Host Protocol

---

The protocol used by a host to communicate with the power supply is described in **Appendix B Mach2 Host Protocol**. It is ASCII based and can be edited in a text editor and sent to the power supply using a terminal program for testing purposes or sent from a PLC or Computer to control the power supply during production.

---

### 6.3.5. Host User Interface

---

The MicroStar Host series power supply comes with a basic user interface called

FrontPanel+ that runs under Microsoft Windows for remotely controlling and monitoring the unit. FrontPanel+ includes an editor for editing setups and the optional recipes. The user interface software comes on a disk for installing the interface and drivers onto a PC computer.

A customized user interface can be created by the system integrator or end user to fit their requirements by implementing the protocol commands in a program, running on a Computer or PLC, that sends them to the power supply. Dynatronix has the ability to create custom user interfaces for our customers.

---

---

### **6.3.6. LabVIEW Driver**

---

---

There is a LabVIEW driver available from Dynatronix for no charge. The driver allows customers that use LabVIEW to conveniently access the commands through the LabVIEW programming environment. Contact Dynatronix Customer Service department for more information.

## 6.4. Analog Control (option)

Analog control and monitoring requires an optional analog control card. The unit is set to analog control by selecting one of the analog control modes in the **SYS, 7>SetControlSource** (UNIT) menu or using the host protocol User Settings command. When the unit is in one of the following control sources, Analog, Panel-Analog, or Host-Analog, output level settings are controlled by the optional analog interface and cannot be modified from the front panel or the host port.

### 6.4.1. Analog Control Connections

See section **5.8 Analog I/O Connections** on page **29** for proper connections for analog control.

### 6.4.2. Analog Output Readbacks

The current and voltage readings from the MicroStar rectifier can be monitored using the analog outputs on the optional analog control card. The analog outputs will always reflect the current and voltage readings. The analog outputs are proportional to the readings as shown in the following tables.

#### Analog Output Level Range

Analog I/O Type	Minimum	Maximum
4 to 20mA	4mA	20mA
0 to 5V	0.0V	5V
0 to 10V	0.0V	10V

#### Analog Output Scaling

Unit Reading	Analog Output Level
0.0 (volts or amps)	Minimum
Supply Voltage Rating	Maximum
Supply Average Current Rating	Maximum

NOTE: The current readback is proportional to the average current rating of a pulsed unit and reflects the average current of the output waveform. For a DC power supply the Peak and Average current ratings are the same.

The voltage readback is proportional the units voltage rating.



---

### 6.4.3. Analog Input Setting Control

---

The MicroStar rectifier's voltage and current settings can be controlled through the analog option card when the power supply is in analog mode. When the power supply is in analog mode the voltage and current settings cannot be adjusted from the front panel or the host. The unit output levels are proportional to the analog input levels as shown in the following tables.

NOTE: The peak settings commanded by the analog inputs can be monitored by pressing the ENTER key to get to a settings screen.

#### Analog Input Level Range

Analog I/O Type	Minimum	Maximum
4 to 20mA	4mA	20mA
0 to 5V	0.0V	5V
0 to 10V	0.0V	10V

#### Analog Input Scaling

Analog Input Level	Unit Setting
Minimum	0.0 (volts or amps)
Maximum (voltage)	Supply Voltage Rating
Maximum (current)	Supply Peak Current Rating

NOTE: The analog input(s) for current setting(s) set the Peak Current value (not average) on a pulsed power supply. For a DC power supply the Peak and Average current ratings are the same.

---

### 6.4.4. Analog Regulation Modes

---

The regulation mode for analog control works in the same fashion as for panel or host control except the controlled levels are set by the analog interface instead of the panel or host. The regulation mode is selected using the **SYS, 2->SetRegulationMode-** (SETUP) menu or using the Setup command via the host port.

For **Current Regulation** the voltage level is automatically preset at the supply's rating. Only the current input(s) on the analog interface need to be driven.

For **Crossover Regulation** both the current and voltage inputs on the analog interface need to be driven.

For **Voltage Regulation** the current level is automatically preset at the supply's rating. Only the voltage input(s) on the analog interface need to be driven. When in voltage regulation mode the supply will automatically limit the current level to keep it within the average rating of the unit.

See section **5.8 Analog I/O Connections** on page **29** for information on the analog interface

connections.

---

---

### 6.4.5. Analog Control Modes

---

---

There are 3 different analog control modes available, Analog, Panel-Analog, or Host-Analog. See section **6.1.7.3. SYS – System Key**, 7>SetControlSource (UNIT) for details. See also the host protocol User Settings command at Appendix **B.22 User Settings Command**: on page 154.

---

---

### 6.4.6. Remote Operate / Standby for Analog Control

---

---

The unit output can be controlled remotely using the Operate input on the Digital I/O connector on the back of the power supply. If the unit is in Analog Control mode this input MUST be used to control the output. If the unit is in Panel-Analog or Host-Analog control mode then using this input is optional. See section **5.6.1.2 Operate Input** on page 26 for proper connections for operation of the operate input. See section **6.1.7.3. SYS – System Key**, 1>StatusandMiscSettings 4>ExtOPRInputOptions (UNIT) for setting the external operate input mode from the front panel or see the User Settings protocol command in Appendix **B.22 User Settings Command**: on page 154.

---

---

### 6.4.7. Dual Range Output (DRO) and Analog Control

---

---

When using analog control with a Dual Range unit some changes in the normal operation need to be considered.

Changing the analog current setting going to the unit will change the range if the current set by the analog input is less than the range change current when in high range (range 0).

When the output is in range 1 (low range) the unit will change ranges if the current reaches the range change level.

These range changes can be a little unpredictable when using analog control due to accuracy of the setting levels, the calibration of the inputs and noise in the system. When the current setting is close to the range change level any noise or inaccuracies could potentially cause the range to switch back and forth continuously. There could also be a problem where the range would not change from low to high if the analog input calibration or setting calibration was off and the setting never reaches the range change level in which case the range would be stuck in low.

## 6.5. Power Fail Operation

The Operate state of the unit is factory set to always go to standby after a power cycle or brown-out condition even if it was in operate. This function can be changed to return to the state that it was in before the power cycle by using the control panel **SYS**, 1>StatusandMisc Settings, 7>SetPowerFailMode - (UNIT) menu or by using the host User Settings command.

If this setting is set to start up in the State Before Power-Fail (persistent operate mode) the unit will recover to its previous operating state (operate, trickle or standby) if it loses power, either by the power switch or a brownout / blackout line condition.

See Section 6.1.7.3. **SYS – System Key**, 1>StatusandMiscSettings, 7>SetPowerFailMode - (UNIT) for more information.

**CAUTION - in PF mode 2 or 3 if the unit is in Trickle state, then when the power is restored the unit will immediately return to the Trickle state. Anyone working with the unit needs to be informed when this mode is selected and that the output can become active automatically when power is restored.**

## 6.6. Options

The MicroStar has many optional features that allow a customer to purchase only the features that are needed for the processes being run. The Options installed in a power supply can be viewed using the **SYS**, 1>StatusandMiscSettings, 2>ShowInstalledOptions menu item. A list of options installed will be shown on the Display. If there are more than 5 options installed, pressing the **ENTER** key will show more options.



Figure 6.41: Options List Screen

The following is a list of the Option abbreviations and a description of the option.

---

### 6.6.1. RMP - Ramp Function

---

This allows the start of a cycle to ramp the current or voltage setting up or down over a period of time starting at a user settable starting offset level. This feature can be accessed via the F1 key. See section 6.1.7.1. **F1 – Function Key 1**, menu items 1> through 3> for more details.

---

### 6.6.2. RLY - Relay Output Control

---

This feature controls a relay that can control a pump to add chemicals to a bath or circulate the plating solution. The pump will come on after a user set amount of Amp Time and remain on for a user set amount of Real Time. This feature can be accessed through the **CYCLE CONTROL** key. See section 5.7 **Relay Connections (pump control)** on page 28 for relay connections and 6.1.7.2. **CYCLE CNTL – Cycle Control Key**, 6>RelayTripPoint (option) for

more details.

The relay can also be set to be on during operate or on during alarm. These settings can be accessed in the **SYS**, 1>StatusandMiscSettings 5>RelayControlOptions- (UNIT)(option) menu described in section **6.1.7.3. SYS – System Key**.

---

---

### 6.6.3. ANL - Analog Control

---

---

This option allows the power supply current and voltage levels to be controlled by analog input levels. Analog output levels report the voltage and current levels at the output of the power supply. The pulsing parameters on pulsing units must be preset using the control panel or host port for this feature to work properly. This feature is enabled via the **SYS** key, 7>SetControlSource- (UNIT) menu item. See section **6.4. Analog Control (option)** for details on analog operation and analog settings and reading levels. See section **5.8 Analog I/O Connections** on page **29** for analog connections.

---

---

### 6.6.4. RCP - Recipe Control

---

---

This optional feature allows the power supply to control complex multi-step plating processes. Recipes work by linking multiple Setups together and running them in sequence. Looping is used to repeat 1 or more steps in a recipe for a preset number of times. This feature is accessed through the **CYCLE CONTROL** key for editing a recipe and the **SAVE / RECALL** key to allow recipes to be saved, recalled and deleted. See section **6.1.7.2. CYCLE CNTL – Cycle Control Key** and **6.2.2. Recipes** for more details.

---

---

### 6.6.5. TKL - Trickle Mode

---

---

This optional feature allows the power supply to output a low level current at the end of a cycle. When enabled, the Trickle function sets the output level to the trickle setting, checks the voltage level at the output and then changes the regulation mode to crossover and sets the voltage setting to the voltage level. This allows a part to be extracted from the bath with a voltage controlled limit on the current so the part is less likely burn. The trickle function works when the operator presses the **STBY** key if the unit is in Manual mode or when the unit goes to Standby at the end of an ATC or RTC cycle. See section **6.1.7.1. F1 – Function Key 1** for more details.

---

---

### 6.6.6. MSV - Master-Slave Control

---

---

This option allows a unit set as a Master to control the timing and operation of a unit set as a Slave. The Master can control up to 9 Slave units. The Master is used to control the waveform timing and ATC, RTC or Manual cycle durations of the Slave units. The Master is used to start and stop cycles using the **OPR/STBY** keys or the remote operate input. See section **5.9 Master-Slave Connections** on page **33** for Master-Slave connections and see section **6.1.3.3. M/S – Master/Slave Menu for Master-Slave option** for more information.

<p>NOTE: If Host control is being used for Master-Slave the settings to run the Slave are sent directly to the Slave. Make sure the Timing is the same for both the Master and the Slave in order to get the proper readbacks from the Slave.</p>
---

---

---

### 6.6.7. DRO – Dual Range Output

---

---

When this option installed at the factory the unit unit has two output ranges. The first range (R0) starts at maximum current rating and goes down to some lower current rating which is the range cutoff current level (typically 10% of peak rating but can be almost any level). When the current is set below the cutoff level the output switches to a more precise current range for better regulation (and pulsing if the unit has pulsing capability) at the lower current levels. The AMPS meter resolution also changes. The switching is automatic and transparent to the user other than the resolution of the current setting and meter. See section 6.1.1.2. **Dual Range Output (option)** on page 37.

NOTE: For reversing units (DPR) with dual range, the current levels for both forward and reverse must be below the range change current level in order for low range to be active.
--

---

## 6.7. Messages

---

The following are messages that may be displayed and their meaning.

---

---

### 6.7.1. Msg01 I Limit: >100ms

---

---

This message is displayed when the pulse On Time is greater than 100ms or set to DC and the current setting is greater than the unit's average current rating (100ms is the maximum pulse duration when running above the average rating of the unit). Either the pulse duration must be decreased to 100ms or below or the current setting must be reduced to the average rating or below.

---

---

### 6.7.2. Msg02 I Limit: Sum > Ave

---

---

This message means that the average forward or reverse current when running single direction or the sum of the average forward and reverse current when running pulse reverse is greater than the unit's average current rating. The sum of the current in both directions cannot be greater than the average current rating of the unit. Reduce the current levels or reduce the duty cycles to keep this message from showing.

If messages like Msg01 and Msg02 are being displayed the best thing to do is to reduce the current settings to a value below the average current rating of the unit. Then adjust the pulsing values to the desired settings. Then readjust the current to the desired level. If the message is displayed when adjusting the current back up, then the desired current cannot be obtained with the pulsing parameters that are set. One or the other will have to change.

---

---

### 6.7.3. Msg03 I Limit: V Reg Duty

---

---

This message shows that the peak current is being automatically reduced because the duty cycle set in voltage regulation mode could cause the output to go beyond the unit's ratings. The current is reduced proportionally to the duty cycle until the average current rating is reached. This is a "for information only" message because the current reduction process is automatic in voltage regulation mode. The current value limit can be viewed in the forward or reverse settings screen. This message will not show if the duty cycle is less than or equal to the average/peak ratings ratio.

---

---

#### **6.7.4. Timing Params Not Valid, Please Recheck Them**

---

---

This message is displayed when the waveform timing settings are not valid for pulsing. This would be displayed if all pulse settings or the ON and OFF times or the DIR times (for a PR unit) are set to 0.

---

---

#### **6.7.5. M-S Err: message**

---

---

These are communications errors that occur when using the Master-Slave option. Check to see that the cable(s) between the master and slave(s) are connected properly and that the slave(s) are powered on. If they persist, contact Dynatronix customer support.

---

---

#### **6.7.6. CM Power Fail Standby - Restarting When Power OK**

---

---

This error occurs when the AC input voltage goes below the allowable minimum value for the controller board in the power supply. Check for loose input power connections and check the AC voltage level at the outlet/breaker supplying the power supply. Also see section **6.1.7.3. SYS – System Key**, 1>StatusandMiscSettings, 7>SetPowerFailMode - (UNIT) for information on the power-fail recovery method.

---

---

#### **6.7.7. Ext. Interlock Is Open - Cannot Operate**

---

---

The power supply cannot operate if the External Interlock jumper on the back of the unit is not connected properly. See section **5.6.1.1 Interlock Enable** on page 26 for more details.

---

---

#### **6.7.8. Power Fail Save Error, Call Dynatronix Service**

---

---

This message will only show up at power-up or after a brown-out. The power supply did not shut down properly when the power failed or was shut off. If this error continues to be displayed, contact Dynatronix Customer Support.

---

---

#### **6.7.9. Settings Defaulted**

---

---

This message is displayed in conjunction with the Power Fail message above. Whenever the power supply does not shut down properly, the settings are defaulted.

## 6.8. Quick Start Guide

---

The power supply typically comes with all setting defaulted to 0 so some settings will have to be set in order to get any output from it.

If the unit is a DC unit (CRS or DC series) only a current level will have to be set to get output. The regulation mode is defaulted to current regulation. In order to set a current level press the **ENTER** key to get to the setting screen and then use the **AMPS up and down arrows** to set the current level.

If the unit is a Pulsing or Reversing unit (DP, DPR, DPD, DuP, DuPR, DuPD, CRSR, CRS-LFP, CRS-LFPR or DCR series) a current level and pulse timing will have to be set to get output. The regulation mode is defaulted to current regulation. In order to set a current level press the **ENTER** key to get to the setting screen(s) and then use the **AMPS Up and Down arrows** to set the current level.

Section **6.8.1. Quick-Start Setup Tips** describes where to find common settings.

Section **6.8.2. Settings and Operation Examples** goes through some examples of how to set up the unit.

---

### 6.8.1. Quick-Start Setup Tips

---

This section is just a basic overview of where to find settings for the unit.

Nothing needs to be preset in order to do the Settings and Operation Examples in Section **6.8.2.** below.

#### 6.8.1.1. PULSE TIMING Menu Key

---

If the unit has pulsing and/or reversing capability then this key's menu controls the shape of the waveform. The menu is not available on DC units (CRS and DC).

In order to get output from a pulsing and/or reversing unit some basic timing settings must be entered.

The simplest timing settings are for DC output. To set DC timing do the following depending on the model type.

- CRSR or DCR reversing only units: Set the Forward Duration to any non-zero value and leave the Reverse Duration 0.
- DP, DuP or CRS-LFP pulsing only units: Set the Fwd On Time to any non-zero value, leave the Fwd Off Time 0.
- DPR, DuPR, or CRS-LFPR pulse reversing units and DPD, DuPD & LFPD dual level units: Set the Fwd On Time to any non-zero value, leave the Fwd Off Time 0. Set the Forward Duration to any non-zero value and leave the Reverse Duration, the Rev On Time and the Rev Off Time set to 0.

See **6.1.7.4. PULSE TIMING – Pulse Timing Key** for more details.

### **6.8.1.2. Output Settings Keys**

---

In order to set the output levels, current and/or voltage, the following keys are used.

The **AMPS Up and Down Arrows** and **VOLTS Up and Down Arrow** keys are used to adjust the output levels.

The levels can only be adjusted when the forward or optional reverse settings screen is showing, these screens are accessed by pressing the **ENTER** key repeatedly. When one of the settings screens is showing, then the **Up and Down arrows** for current and/or voltage can be pressed in order to adjust that level.

When finished adjusting the level, press the **ENTER** key to get back to the settings screen or the **ESC** key to get back to the Main screen.

Note that depending on the regulation mode, either voltage or current may not be able to be adjusted, see **6.1.7.3. SYS – System Key, 2>SetRegulationMode- (SETUP)**

See **6.1.3. VOLTS Arrow Keys** and **6.1.5. AMPS Arrow Keys** for more details.

### **6.8.1.3. CYCLE CNTRL Menu Key**

---

Use the menus under the **CYCLE CONTROL** key to set up how a job's cycle is run.

A cycle can be controlled Manually, by a Real Time Cycle (RTC) or by an Amp-Time Cycle (ATC).

A cycle controlled manually (default) will show Manual on the second line of the display. Using manual control, the operator presses the **OPR** key in order to get output from the power supply and presses the **STBY** key to stop the output.

A cycle controlled by RTC (seconds, minutes, hours) is set by selecting **1>RealTimeCycle(RTC)** from the **CYCLE CNTRL** menu and adjusting the value using the **UP (5)** and **DOWN (0) Arrow** keys.

A quick way to set an RTC is by pressing the **UP (5) Arrow** key when Manual is showing on the Main screen.

A cycle can be controlled by ATC (amp-minutes, amp-hours) by selecting **2>AmpTimeCycle (ATC)** from the **CYCLE CNTRL** menu and adjusting the value using the **UP (5)** and **DOWN (0) Arrow** keys.

A quick way to set an ATC is by pressing the **DOWN (5) Arrow** key when Manual is showing on the Main screen.

An ATC or RTC cycle can be set back to manual by adjusting its value to 0 and pressing **ENTER**.

The **CYCLE CNTRL** menu is also used to set things like the optional Recipe and Recipe Looping mode, an optional Amp-Time controlled relay, viewing and clearing the main totalizer(s), and to set whether ATC cycles accumulate forward current only or does forward minus reverse current accumulation on reversing power supplies.

See **6.1.7.2. CYCLE CNTRL – Cycle Control Key** and its sub-menus for more details.



#### **6.8.1.4. SYS Menu Key**

---

Use the menus under the SYS key to set up the unit for basic operation parameters.

See **6.1.7.3. SYS – System Key** and its sub-menus for more details.

1>StatusandMiscSettings is used to set general system setting like how the external operate input works, how the relay option works, the power fail recovery method and the host port settings.

2>SetRegulationMode- (SETUP) is used to set the power supply's output regulation method: current regulation, crossover regulation or voltage regulation.

3>SetCurr & VoltTol- (SETUP) is used to set a value in % of setting that will cause the meter to flash, and an alarm to sound if the tolerance alarm is enabled using the ALARM/SILENCE key.

4>SetResolutions- (SETUP) is used to set the resolution of settings made for the Totalizer, Real Time cycles, Amp Time cycles, Pulse and Reversing Timing, Ramp Time and Current.

7>SetControlSource- (UNIT) is used to select the control mode, either Panel, Host, Analog, Panel-Analog or Host Analog.

#### **6.8.1.5. SAVE / RECALL Key**

---

Use the items under the **SAVE / RECALL** key to save, recall or delete a set of settings called a Setup. All the settings that can control a cycle are saved to the Setup and can be recalled when needed.

This menu also has choices to save, recall or delete recipes if the recipe option is installed.

See **6.1.7.5. SAVE / RECALL – Save and Recall Key** and **6.2.1. Setups** for more details.

#### **6.8.1.6. ALARM / SILENCE Key**

---

The items under the ALARM / SILENCE key can be used to enable and disable various alarms. When an alarm is sounding, press the ALARM / SILENCE key to silence the alarm and the display will show the cause(s) for the alarm(s).

The 1>EOCAlam(End Of Cycle), when enabled will sound an alarm whenever an ATC or RTC cycle is finished.

The 2>IerrAlam(Current Out of Tolerance Error), when enabled will sound an alarm whenever the current level goes out of the tolerance window set by using the **SYS**, 3>SetCurr & VoltTol- (SETUP) menu item.

The 3>VerrAlam(Voltage Out of Tolerance Error), when enabled will sound an alarm whenever the voltage level goes out of the tolerance window set by using the **SYS**, 3>SetCurr & VoltTol- (SETUP) menu item.

The optional 4>RelayAlam(Relay is On), when enabled will sound an alarm whenever the relay turns on during an Amp-Time Controlled Relay cycle. This can also sound depending on how the Relay Output is configured in the **SYS**, 1>, 5>RelayControlOptions- (UNIT)(option) menu item.

See **6.1.7.6. ALARM / SILENCE – Alarm Key** for more details.

---

### 6.8.1.7. F1 Key

---

The items under the F1 key are options used for controlling ramping and trickle.

See **6.1.7.1. F1 – Function Key 1** for more details.

---

## 6.8.2. Settings and Operation Examples

---

Some basic Settings and Operation examples for the unit are described below. Go through the tests below in the order shown for the settings to work properly.

For a CRS or DC (DC only) unit follow the DC flow.

For a CRSR or DCR (reversing only) unit follow the DCR flow

For a DP, DuP or CRS-LFP (pulsing only) unit follow the DP flow.

For a DPR, DuPR, DPD, DuPD or CRS-LFPR (pulse reverse/dual lvl) unit follow the DPR flow.

---

### 6.8.2.1. DC output test (all units)

---

1. Connect a load to the output of the power supply that can handle the supply's ratings.
2. Turn on the unit using the breaker switch on the front panel for larger units or, for small DuP style units, the switch on the back just above the input line cord.
3. The unit is supplied with all settings defaulted and set to zero so output level(s) must be set on all units and timing must be entered on pulsing and/or reversing units. For DC units, go to **12..**
4. Press the **PULSE TIMING** key if the unit has pulsing and/or reversing capability. For DCR units go to **9..**
5. For DP and DPR units, select 1>SetForwardOnTime using the **UP** and **DOWN Arrow** keys and press **ENTER**.
6. Use the **UP** and **DOWN Arrow** keys to set a non zero time, say 4.00ms and press **ENTER**. For DP units, go to **11..**
7. For DPR units select 3>SetForwardDuration using the **UP/DOWN Arrow** keys and then press the **ENTER** key.
8. Use the **UP and DOWN Arrow** keys to set a non zero time, say 8.00ms and press **ENTER**. For DPR units go to **11..**
9. For DCR units select 1>SetForwardDuration using the **UP/DOWN Arrow** keys and then press the **ENTER** key.
10. Use the **UP and DOWN Arrow** keys to set a non zero time, say 3s and press **ENTER**.
11. Press **ESC** and the Main screen will show.
12. Press the **ENTER** key once and the Forward Settings screen will appear. Notice that the forward duty cycle is 100% due to the timing settings entered and not setting a forward off time (if the unit has pulsing) and no reverse settings (if the unit has reverse).
13. Press the **AMPS UP Arrow** key to set a low test current level of say 10% of rating (the default regulation mode is current).
14. Press the **ENTER** key to accept the current setting.
15. The unit is now ready to run a DC output at the current setting shown on the display.

16. Press the **OPR** key to turn on the unit's output.
17. The meters should show an output current and voltage depending upon the load being used.
18. Press the **STBY** key to turn the output off.
19. For DC units, go to **6.8.2.5**. For DCR style units go to **6.8.2.2**, otherwise for DP or DPR units proceed to **6.8.2.3**.

### 6.8.2.2. Reversing only output test (DCR, reversing only units only)

1. Press the PULSE TIMING key.
2. Select 2>SetReverseDuration using the **UP and DOWN Arrow** keys and press **ENTER**.
3. Use the **UP and DOWN Arrow** keys to set a non zero time, say 1s, and press **ENTER**.
4. Press **ESC** and the Main screen will show.
5. Press the **ENTER** key once and the Forward Settings screen will appear. Notice that the forward duty cycle is still 100% and the effective forward duty cycle is 75% due to the timing settings entered and calculated by  $3/(3+1)$ .
6. Press the **ENTER** key once and the Reverse Settings screen will appear. Notice that the reverse duty cycle is also 100% because this is a DC unit with reverse (no pulsing) and that the effective reverse duty is 25% which is calculated by  $1/(3+1)$ .
7. Press the **AMPS UP Arrow** key to set the reverse current to the same value as the forward current set above (10% of current rating).
8. Press the **ENTER** key to accept the current setting.
9. Press **ESC** to get to the main screen. Notice that the Effective Plate Current is  $\frac{1}{2}$  the forward current setting. This is due to the settings and the effective plating current calculated by  $(\text{fwd curr} * \text{eff fwd duty cycle} - \text{rev curr} * \text{eff rev duty cycle})$  (ie, if the fwd & rev current was 10 Amps,  $10A * 0.75 - 10A * 0.25 = 5A$ ).
10. Press the **ENTER** key once to get to the Forward Settings screen.
11. Press the **AMPS UP Arrow** key to set the forward current to a value twice as large as entered before, say 20% of unit rating.
12. Press the **ENTER** key to accept the current setting.
13. Now the Effective Plate Current is much higher because only the forward current was increased (ie,  $20A * 0.75 - 10A * 0.25 = 12.5A$ ). Now there will be more forward plating current than reverse deplating current
14. Press the **OPR** key to turn on the unit's output.
15. The meters should show an output current and voltage depending upon the load being used and the output will be running fwd current for 3 seconds and reverse current for 1 second if the settings described above were entered..
16. The meters show the Effective values when the Main screen is showing. Press the **ENTER** key once to display the Forward screen. Now the meters will show the Average Forward output values only. Press the **ENTER** key one more time to display the Reverse screen. The meters now show the Average Reverse output values. Press the **ENTER** key once and you will be back to the Effective values. Notice that the Effective values equal the Average Forward minus the Average Reverse values.
17. Press the **STBY** key to turn the output off. For DCR units, go to **6.8.2.5**.

### **6.8.2.3. Pulsing output test (DP, pulsing units only)**

---

1. Press the **PULSE TIMING** key.
2. Select 2>SetForwardOffTime using the **UP and DOWN Arrow** keys and press **ENTER**.
3. Use the **UP and DOWN Arrow** keys to set a non zero time, say 4.00ms.
4. Press **ENTER** and then **ESC** and the Main screen will show.
5. Press the **ENTER** key once and the Forward Settings screen will appear. Notice that the forward duty cycle is now 50% due to the pulsing settings entered.
6. Press **ESC** to get to the main screen. Notice that the Effective Plate Current is 50% of the current setting entered above for the DC settings due to the pulse timing values having a 50% duty cycle.
7. Press the **OPR** key to turn on the unit's output.
8. The meters should show an output current and voltage depending upon the load being used and about half the value that showed when running the DC settings above.
9. Press the **STBY** key to turn the output off. For DP units, go to **6.8.2.5**.

### **6.8.2.4. Pulse Reverse output test (DPR, pulse reverse units only)**

---

1. Press the **PULSE TIMING** key.
2. Select 4>SetReverseDuration using the **UP and DOWN Arrow** keys and press **ENTER**.
3. Use the **UP and DOWN Arrow** keys to set a non zero time, say 8.00ms, and press **ENTER**.
4. Select 5>SetRevOnTime using the **UP and DOWN Arrow** keys and press **ENTER**.
5. Use the **UP and DOWN Arrow** keys to set a non zero time, say 4.00ms, and press **ENTER**.
6. Select 6>SetRevOffTime using the **UP and DOWN Arrow** keys and press **ENTER**.
7. Use the **UP and DOWN Arrow** keys to set a non zero time, say 4.00ms, and press **ENTER**.
8. Press **ENTER** and then **ESC** and the Main screen will show.
9. Press the **ENTER** key once and the Forward Settings screen will appear. Notice that the forward duty cycle is now 50% and the effective forward duty cycle is 25% due to the pulsing settings entered.
10. Press the **ENTER** key once and the Reverse Settings screen will appear. Notice that the reverse duty cycles are the same as the forward duty because the settings are the same.
11. Press the **AMPS UP Arrow** key to set the reverse current to the same value as the forward current set above.
12. Press the **ENTER** key to accept the current setting.
13. Press **ESC** to get to the main screen. Notice that the Effective Plate Current is 0 (zero). This is due to the reverse settings being the same as the forward settings resulting in no effective plating current.
14. Press the **ENTER** key once to get to the Forward Settings screen.
15. Press the **AMPS UP Arrow** key to set the forward current to a value twice as large as entered before, say 20% of unit rating.
16. Press the **ENTER** key to accept the current setting.
17. Now the Effective Plate Current will be a positive value due to more forward plating current than reverse deplating current.

18. Press the **OPR** key to turn on the unit's output.
19. The meters should show an output current and voltage depending upon the load being used and about one quarter the value that showed when running the DC settings above.
20. The meters show the Effective values when the Main screen is showing. Press the **ENTER** key once to display the Forward screen. Now the meters will show the Average Forward output values only. Press the **ENTER** key one more time to display the Reverse screen. The meters now show the Average Reverse output values. Press the **ENTER** key once and you will be back to the Effective values. Notice that the Effective values equal the Average Forward minus the Average Reverses values.
21. Press the **STBY** key to turn the output off.

#### **6.8.2.5. Real Time Controlled (RTC) cycle setup**

---

1. Press the **UP Arrow** key to quickly set an RTC cycle. (Timed cycles can also be set up using the **CYCLE CNTRL** key.)
2. Use the **UP and DOWN Arrow** keys to adjust the time to 5 seconds.
3. Press the **ENTER** key to accept the time.
4. The main screen will show a 005.0s real time cycle period.
5. Press the **OPR** key to run this 5 second cycle.
6. At the end the unit will automatically turn off it's output and go to standby. Press the **ESC** key to clear the flashing display.

#### **6.8.2.6. Amp Time Controlled (ATC) cycle setup**

---

1. Now press the **DOWN Arrow** key until the RTC setting is 0.
2. Press the **ENTER** key and the main screen will show that the RTC control is canceled and the unit is back to Manual control.
3. Press the **DOWN Arrow** key again and the display will go to the quick ATC cycle setting screen.
4. Press the **UP Arrow** key and set a small amp time value, say 1% of the current rating of the unit in Amp Minutes (Am) (i.e. if the unit is rated at 50 amps then set a value of 5.0Am).
5. Press the **ENTER** key to accept this setting.
6. The main screen will show a 5.0Am amp time cycle setting.
7. Press the **OPR** key to run this 5.0Am cycle.
8. At the end of this ATC cycle the unit will automatically turn off it's output and go to standby. Press the **ESC** key to clear the flashing cycle done display.

### 6.8.2.7. Using Setups

---

This section describes how to save and recall Setups. See Section 6.2. Programming and 6.2.1. Setups for more information.

1. Press the **SAVE/RECALL** key.
2. Select 1>SaveSetup using the **ENTER** key.
3. The bottom line of the screen will show numbers 01 to 05 with either an 'e' or a space to the right of them. The 'e' indicates that the location is empty while a space would show that the location has something saved in it.
4. Enter a setup number, using the number keys, to set the location where the current settings will be saved to, say 02 (both digits must be entered).
5. Press the **ENTER** key and the setup will be saved and the display will show a message indicating that.
6. Press **ENTER** again to get back to the SAVE/RECALL menu
7. Press **ESC** to get back to the main screen. You will notice that the Setup number has changed from XX to 02.
8. Press the **DOWN** Arrow key to set the ATC to 0 and press **ENTER** to get Manual mode. You will notice that a \* is next to the Setup 02 showing that the setup has changed.
9. Press the **SAVE/RECALL** key.
10. Select 1>SaveSetup using the **ENTER** key.
11. Enter a setup number to set the location the current settings will be saved to, say 03.
12. Press the **ENTER** key and the setup will be saved.
13. Press **ENTER** again to get back to the SAVE/RECALL menu
14. Select 2>RecallSetup
15. Enter 02 and press **ENTER**.
16. The screen will show a message asking if you wish to load this setup. Press **ENTER** to load it and then **ESC** and **ESC** to get back to the main screen.
17. The main screen shows that the setup with the ATC cycle has been recalled.
18. Repeat the recall for setup 03 and the Manual cycle setup will be recalled.
19. To delete a setup, select 3>DeleteSetup from the **SAVE/RECALL** menu and enter 02 and press **ENTER**.
20. The screen will show a message asking for confirmation to delete the setup. Press the **ENTER** key and the setup will be deleted. Press **ESC** to get back to the SAVE/RECALL menu.
21. Press **ESC** again to get back to the main screen. Notice that the settings for the deleted setup are still there but the Setup number has changed to XX because the setup is deleted from memory.
22. Try recalling setup 02 and a message will be displayed saying it was deleted or not saved.

### 6.8.2.8. Creating a Recipe

---

A recipe is created using one or more setups that have been saved. The setups should have an ATC or RTC cycle set so that the recipe can run through automatically (if the setup has a Manual cycle the recipe will stop there and require user intervention to continue). See Section 6.2.2. **Recipes** for more information.

1. Create one or more setups for the recipe and save them.
2. Press the **CYCLE CNTRL** key and use the **UP and DOWN Arrow** keys to select 3>SetRecipe Cycle and press **ENTER**.
3. Enter the setup numbers of the setups created in step 1. Setup numbers must always be entered using 2 digits, to enter setup 01 press **Number Keys** 0 and then 1. When both digits are entered the cursor will move to the next step.
4. When finished entering setup numbers into the steps press the **ESC** key twice to get back to the main screen. The screen will show that the recipe mode is active by displaying Rcp#XX in the upper right corner.
5. The recipe is ready to run as long as looping is not required. To run it press the **OPR** key. The recipe will run each step in sequence and then stop after the last step.
6. If looping is required press the **CYCLE CNTRL** key and use the **UP and DOWN Arrow** keys to select 4>SetRecipeLooping and press **ENTER**.
7. This screen is where looping is set for recipe steps. Use the **Right Arrow** (VOLTS Up) key to cycle through the steps in the recipe. Stop at the step for which looping is required.
8. The number on the top line is the number of times to run this step while looping. It is adjusted using the **UP and DOWN Arrow** keys when the flashing cursor is next to it. Adjust it to the required number.
9. Press the **ENTER** key to move the cursor to the second line where the 'step number to jump to' is adjusted. Use the **Number Keys** to set the step that will be jumped to when this step is done (the recipe can only jump to steps preceding the active step).
10. Repeat steps 7 and 9 for any other steps that require looping.
11. Press **ESC** twice to get back to the main screen.
12. The recipe with looping is ready to run. Press **OPR** to start it. The recipe will run each step in sequence unless the step has looping. When a step with looping is reached it will run that step then jump to the step number set in 9 above. When that step and any steps between it and the step that has the looping is complete the step with the looping will run again. When it is finished if it has not run the number of times set in 8 above it will repeat the jump process otherwise if it has run the correct number of times it will continue on to the next step in the recipe. See Section 6.2.2.5. **Looping Recipe Steps** for more information.

### 6.8.2.9. Using System Settings

---

This section describes setting up the system for the process being run.

#### 6.8.2.9.1. Set the Regulation Mode.

---

Regulation mode controls which signal, current or/and voltage, is in control of the output of the power supply. See section 6.1.7.3. **SYS – System Key**, 2>SetRegulationMode- (SETUP) for more information on the regulation modes.

1. Press the **SYS** button and select the 2>SetRegulationMode- (SETUP) menu item.
2. Select one of the following regulation modes using the **UP and DOWN Arrow** keys and the **ENTER** key.
  - 2.1. Current Reg - regulates current to the user set limit and allows the voltage to follow the load resistance changes but will max out at the power supplies rated voltage.
  - 2.2. Crossover Reg - regulates both current and voltage so they do not go beyond the user set limits. Only one of the levels is regulated at any given them while the other one follows the load resistance changes.
  - 2.3. Voltage Reg - regulates voltage to the user set limit and allows the current to follow the load resistance changes up to the power supplies current rating (peak or average depending on pulsing settings so as to not exceed the average current rating of the unit).

#### 6.8.2.9.2. Set the Current and Voltage Tolerance.

---

Current and voltage tolerance controls how far the output level can be off from the settings before an alarm is activated (if enabled). See section 6.1.7.3. **SYS – System Key**, 3>SetCurr & VoltTol- (SETUP) for more information.

Be careful when setting tolerances to very low percentages, as many processes can vary depending on bath structure.

Note: When in Current regulation mode the voltage setting is set to unit voltage rating and in Voltage regulation mode the current can be automatically set to a variable value from the average current rating up to the peak current rating depending on the timing settings (for pulsed units).

1. Press the **SYS** button and select the 3>SetCurr & VoltTol- (SETUP) menu item.
2. Select one of the following tolerance settings using the **UP and DOWN Arrow** keys and the **ENTER** key.
  - 2.1. Current Tolerance - sets the range, in +/- % of setting, that the output current can vary from the setting. If the output current goes above or below that range then the unit will flash the AMPS meter if the unit has a panel connected to it and/or set the Current Tolerance flag in the Alarm command for the host. If the audible Current Error alarm is enabled then the alarm will sound also.
  - 2.2. Voltage Tolerance- sets the range, in +/- % of setting, that the output voltage can vary from the setting. If the output voltage goes above or below that range then the unit will flash the VOLTS meter if the unit has a panel connected to it and/or set the Voltage Tolerance flag in the Alarm command for the host. If the audible Voltage Error alarm is enabled then the alarm will sound also.



### **6.8.2.9.3. Set the desired Settings Resolutions.**

---

Resolutions control the range and precision that a given timer or totalizer can span. For example the ATC timer has 4 digits of resolution but the user can select from 8 ranges in Amp Minutes and Amp Hours. See section **6.1.7.3 SYS – System Key, 4>SetResolutions- (SETUP)** for more details.

1. Press the SYS button and select the 4>SetResolutions- (SETUP) menu item.
2. The following resolution items can be set.
  - 2.1. Totalizer is the main user totalizer that can be reset when desired. This also controls the resolution of the optional ATC Relay control.
  - 2.2. Real Time timer (RTC) controls the duration of a timed cycle in real time (seconds, minutes, hours).
  - 2.3. Amp Time timer (ATC) controls the duration of a timed cycle in amp time (amp-minutes, amp-hours).
  - 2.4. Forward and Reverse Direction times control the duration of a given direction when reversing or pulse reversing (only for Reversing or Pulse Reversing units).
  - 2.5. On and Off Pulse times controls the duration of pulses on time and the off time between pulses (only for Pulsing or Pulse Reversing units).
  - 2.6. Ramp Time sets the resolution of the ramp time in seconds or minutes for the optional ramping feature.
  - 2.7. Current resolution can be used to reduce the resolution of the current setting and the meter reading. This would be used if less than the full resolution is desired.
3. Use the **UP and DOWN Arrow** keys and the **ENTER** key to select the desired item and set the desired resolutions for each item.
4. When done use the **ESC** key to get back to the main screen.
5. Note that the resolutions set here are saved in the setup parameters. If a setup with different resolutions is recalled then those resolutions will be in effect.

---

### 6.8.3. MicroStar Pulse Setup and Recipe Worksheets

---

Use the following as an aid in programming Setups and Recipes. There are definitions of Setups and the optional Recipes and Looping. There are also some worksheets to aid in keeping track of the settings used for setups and recipes.

**Setup:** A set of saved settings for a plating cycle. A setup can become an individual recipe step if the Recipe option is installed.

Save a set of plating settings as a setup in menu item 1>SaveSetup under the **SAVE/RECALL** button.

There are 10 setup locations that can be used. Each setup can be used in any or all of the 8 available recipes. Note that if one setup is changed and that setup is used in two recipes then both recipes will be changed.

**Recipe:** A series of setups. Each step of the recipe is a setup.

Build the recipe by adding setups in the proper sequence. Use menu item 3>Set RecipeCycle under the **CYCLE CONTROL** button. Assign a setup to each step of the recipe.

Save the recipe in menu item 1>SaveSetup under the **SAVE/RECALL** button.

There are 8 recipe locations capable of 8 steps each. Note that if one setup is changed and that setup is used in two recipes then both recipes will be changed.

Press the **ESC** key once or twice to get out of the recipe edit mode and back to the Main screen.

**Looping:** Jumping from one step back to another within a recipe from one time up to 9999 times.

Set looping between recipe steps using menu item 4>SetRecipeLooping under the **CYCLE CONTROL** button.

Use the **Up** and **Down** Arrow (0 and 5) keys to increase/decrease the Number of Times to run this step. If it is set to 1 then there is no looping and when the step is done it will move to the next step.

Use the **ENTER** key to switch between the Times and the JmpToStep settings.

Use the **Up** and **Down** Arrow (0 and 5) keys to change the step number to jump to.

Use the **Right Arrow** (VOLTS Up) key under the voltmeter to switch to the next step in the recipe. If at the last step then pressing this key will switch to the first step.

Press the **ESC** key once or twice to get out of the looping edit mode and back to the Main screen.

Remember to save a setup or recipe after changing it, otherwise all changes will be lost should you recall another setup or recipe.

Exit Recipe mode (return to manual plating) using menu item 5>SetManualCycle under the **CYCLE CONTROL** button.

Use the worksheets below, to test and develop setups and recipes. Contact Dynatronix Customer Support with any questions.

### 6.8.3.1. Setup Settings Worksheet

Settings Trial # _____ Setup # _____		
Process Name:		
<b>Forward</b>	<b>Reverse (option)</b>	
I Setting:	I Setting:	
V Setting:	V Setting:	
Dir Time (opt):	Dir Time:	
On Time:	On Time:	
Off Time:	Off Time:	
Fwd Duty Cycle %:	Rev Duty Cycle %:	
Regulation Mode: I V X		
Cycle Control: Man RTC ATC	Cycle Duration:	
Current Tolerance %:	Voltage Tolerance %:	
Ramp (opt): Disable Up Down	Time:	Offset:
Trickle (opt): No Yes	Level, % of Fwd I:	
Relay (opt): No Yes	Trip AT:	On Time:
Notes:		

Settings Trial # _____ Setup # _____		
Process Name:		
<b>Forward</b>	<b>Reverse (option)</b>	
I Setting:	I Setting:	
V Setting:	V Setting:	
Dir Time (opt):	Dir Time:	
On Time:	On Time:	
Off Time:	Off Time:	
Fwd Duty Cycle %:	Rev Duty Cycle %:	
Regulation Mode: I V X		
Cycle Control: Man RTC ATC	Cycle Duration:	
Current Tolerance %:	Voltage Tolerance %:	
Ramp (opt): Disable Up Down	Time:	Offset:
Trickle (opt): No Yes	Level, % of Fwd I:	
Relay (opt): No Yes	Trip AT:	On Time:
Notes:		

Settings Trial # _____ Setup # _____		
Process Name:		
<b>Forward</b>	<b>Reverse (option)</b>	
I Setting:	I Setting:	
V Setting:	V Setting:	
Dir Time (opt):	Dir Time:	
On Time:	On Time:	
Off Time:	Off Time:	
Fwd Duty Cycle %:	Rev Duty Cycle %:	
Regulation Mode: I V X		
Cycle Control: Man RTC ATC	Cycle Duration:	
Current Tolerance %:	Voltage Tolerance %:	
Ramp (opt): Disable Up Down	Time:	Offset:
Trickle (opt): No Yes	Level, % of Fwd I:	
Relay (opt): No Yes	Trip AT:	On Time:
Notes:		

Settings Trial # _____ Setup # _____		
Process Name:		
<b>Forward</b>	<b>Reverse (option)</b>	
I Setting:	I Setting:	
V Setting:	V Setting:	
Dir Time (opt):	Dir Time:	
On Time:	On Time:	
Off Time:	Off Time:	
Fwd Duty Cycle %:	Rev Duty Cycle %:	
Regulation Mode: I V X		
Cycle Control: Man RTC ATC	Cycle Duration:	
Current Tolerance %:	Voltage Tolerance %:	
Ramp (opt): Disable Up Down	Time:	Offset:
Trickle (opt): No Yes	Level, % of Fwd I:	
Relay (opt): No Yes	Trip AT:	On Time:
Notes:		

**6.8.3.2. Recipe Settings Worksheet**

<b>Recipe trial #</b> _____		<b>Recipe #</b> _____			
<b>Process Name:</b>					
Step #	Setup #	Looping?	Loop to Step #	Number of Times to Run this Step	Notes
1		Y N			
2		Y N			
3		Y N			
4		Y N			
5		Y N			
6		Y N			
7		Y N			
8		Y N			

<b>Recipe trial #</b> _____		<b>Recipe #</b> _____			
<b>Process Name:</b>					
Step #	Setup #	Looping?	Loop to Step #	Number of Times to Run this Step	Notes
1		Y N			
2		Y N			
3		Y N			
4		Y N			
5		Y N			
6		Y N			
7		Y N			
8		Y N			

<b>Recipe trial #</b> _____		<b>Recipe #</b> _____			
<b>Process Name:</b>					
Step #	Setup #	Looping?	Loop to Step #	Number of Times to Run this Step	Notes
1		Y N			
2		Y N			
3		Y N			
4		Y N			
5		Y N			
6		Y N			
7		Y N			
8		Y N			

## 7. Calibration

### 7.1. Overview

The MicroStar interface utilizes digital trimming techniques rather than discrete trim pots. Calibrating these units is accomplished by adjusting trim settings for each calibration parameter through the MicroStar interface.

There are up to 32 calibration parameters for a MicroStar unit with analog control. Only the output settings need to be manually calibrated through the interface. The input readings are calibrated automatically reducing the calibration time by about half. **Table 1** shows the number of calibration values for various units. The calibration values are written into non volatile memory where they are retained permanently.

Unit Features	# of Manual Calibration Values	# of Automatic Calibration Values	Total Number of Cal Values
Forward only or DC	4	4	8
Fwd + Analog	8	8	16
Fwd + Reverse	8	8	16
Fwd + Rev + Analog	16	16	32

**Table 1 Calibration Values by Unit Features**

Calibration accuracy is measured by certified test equipment connected externally, and the supply enclosure does not have to be entered. Calibration equipment required are a meter, a current shunt and a load as described below.

**CAUTION: All automatic calibrated values require that there be an input to the unit for the same signal for which the output is being calibrated (they are calibrated at the same time). This holds true for Analog Option board calibration also. For example if the forward voltage 100% analog output is being calibrated then it is required that the forward voltage analog control input have a 100% level going into it. If this is not followed the Meters will not work properly.**

## 7.2. Equipment

---

---

### 7.2.1. Meter(s)

---

---

One or two calibrated Digital Volt Meters (DVMs) of at least 4.5 digit resolution and .01% overall accuracy. Using 2 meters is faster when switching from current to voltage calibration but is not necessary.

### 7.2.2. Current Shunt

---

---

A certified shunt with a temperature coefficient of no more than 5 ppm should be used. It is recommended that a 100 mV shunt which is rated at an even power of ten (1A, 10A, etc.) be used. This will require less conversion of the meter reading, requiring only decimal point placement. The rating of the shunt should be at least 1.25 times greater than the average current rating of the power supply. Certified shunts are available from most shunt manufacturers including:

EMPRO MANUFACTURING COMPANY INC.

P.O. BOX 26060

INDIANAPOLIS, IN. 46226

PHONE: (317) 823 4478

Part Number MLA 1 100 for a 1Amp, 100mV Shunt

---

---

### 7.2.3. Loads

---

---

The load should be a resistor of approximately twice the required wattage to prevent injury to personnel or equipment and to prevent significant temperature drift. When calibrating the current settings, a value should be chosen which allows approximately 50% of the voltage at the rated current of the power supply.

When calibrating the voltage settings, the value should allow for 50% of the current at the rated voltage of the power supply. An adjustable carbon pile load works well.

**example:** Power supply rating is 12-100 (12 Volts at 100 Amps average current), or 12-100-400 (12 Volts at 100 Amps average and 400 Amps peak current). Use the average current value when calculating the required load for calibration.

**Current Calibration Load:** The voltage developed across the load should be approximately 6 volts (½ the volt rating) at 100 amps average current.

To determine the resistor value use Ohms law:

$$\frac{6 \text{ Volts}}{100 \text{ Amps}} = 0.06 \text{ Ohms}$$

To determine the actual wattage use:

$$6 \text{ Volts} \times 100 \text{ Amps} = 600 \text{ Watts}$$

To calibrate the current settings it will be necessary to connect a load resistor with a value of **0.06 ohms and 1200 watts**. (twice the actual wattage value for safety).

**Voltage Calibration Loads:** The current developed across the load should be 50 amps (½ the average current rating) at 12 volts.

To determine the resistor value use Ohms law:

$$\frac{12 \text{ Volts}}{50 \text{ Amps}} = 0.24 \text{ Ohms}$$

To determine the actual wattage use:

$$12 \text{ Volts} \times 50 \text{ Amps} = 600 \text{ Watts}$$

To calibrate the voltage settings it will be necessary to connect a load resistor with a value of **0.24 ohms and 1200 watts**. (twice the actual wattage value for safety).

## 7.3. Output Calibration

### 7.3.1. Setup

This section describes setting up the unit for calibration.

1. Connect the calibration load, shunt and meter(s) to the output of the power supply as shown in **Figure 7.1** below.
2. With the unit in STANDBY press the **SYS** key.
3. Use the **ARROW** keys to scroll to 5>CalibrateSets/Reads and press **ENTER**.
4. Enter the 4 digit password (the default is 0000).
5. Use the **ARROW** keys to select the parameter being calibrated.
- 6.

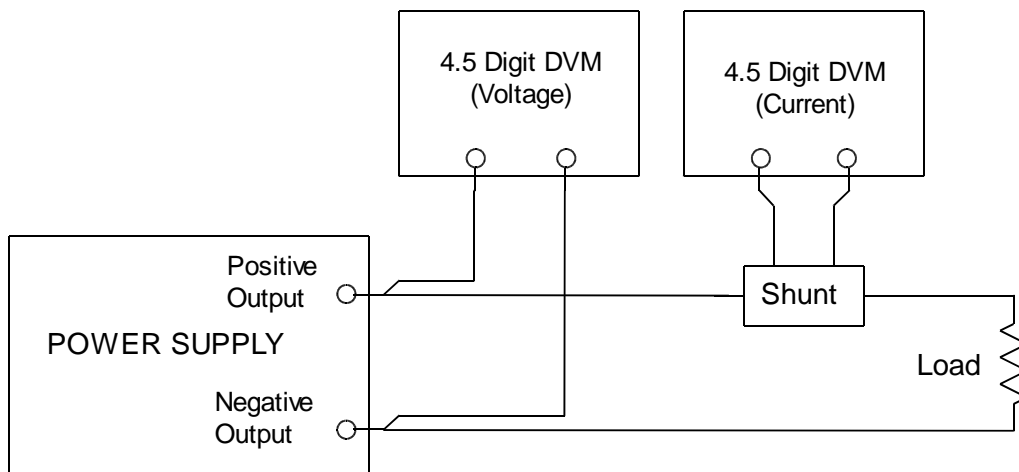

Figure 7.1: Output Calibration Connections



---

---

### 7.3.2. Current Output Calibration - Forward

---

---

1. Connect the appropriate load for current calibration as determined in section 7.2.3 to the power supply as shown in section 7.3.1. **above**.
2. Use the **ARROW** keys to select 1>CalHi FwdI OutR0\ and press **ENTER**.
3. Use the **ARROW** keys to adjust the calibration value until the output current on the meter connected to the shunt reads the proper value for 100% of the average current rating of the supply. (Example: For a DP(R)20-30-100 using a 100A/100mV shunt, 100% of the average current rating of the supply will be 30mV).

NOTE: Adjusting the calibration value UP will bring the output current UP and vice versa.

4. When the meter reading is correct press the **ENTER** key.

NOTE: The READING calibration value is taken when the **ENTER** key is pressed. **Allow at least 1 second after the calibration value is adjusted before pressing the ENTER key** to allow the output and readback to stabilize.

5. Use the **ARROW** keys to select 2>CalLoFwdI OutR0\ and press **ENTER**.
6. Use the **ARROW** keys to adjust the calibration value until the output current on the meter connected to the shunt reads the proper value for 10% of the average current rating of the supply. (Example: For a DP(R)20-30-100 using a 100A/100mV shunt, 10% of the average current rating of the supply will be 3mV).
7. When the meter reading is correct press the **ENTER** key.
8. Repeat steps 2 through 7 as necessary to recheck the calibration.
9. When finished with calibration pressing the **ESC** key will bring up a screen asking if you would like to save the cal table to flash memory or not. Press **ENTER** to save it or **ESC** to not save the changes that were made during calibration.

NOTE: Saving the calibration table saves the values in RAM to Flash. The changes made during calibration are part of the calibration table in RAM memory and will be lost if not saved when exiting the calibration mode.

---

---

### 7.3.3. Current Output Calibration – Reverse (option)

---

---

If the Reverse Option is installed, the Reverse Current Output is calibrated in the same way as Forward by using the **ARROW** keys to select

3>CalHi RevI OutR0\ and

4>CalLoRevI OutR0\ menu items.

---

---

### **7.3.4. Current Output Dual Range Calibration, Range 1 (low range)**

---

---

Units with the Dual Range Option (DRO) require that the extra range, range 1 or low range (the high current range is called range 0), be calibrated separately since it has its own circuitry. Use the following menu items to calibrate it. Make sure the loads are appropriate for the current rating of the low range.

9>CalHi FwdI OutR1\  
10>CalLoFwdI OutR1\  
11>CalHi RevI OutR1\  
12>CalLoRevI OutR1\  
13>CalHi RevI OutR2\  
14>CalLoRevI OutR2

For units with Reverse and the Dual Range Option (DRO) use the following menu items to calibrate the current for the reverse range 1 output levels.

11>CalHi RevI OutR1\  
12>CalLoRevI OutR1\  
13>CalHi RevI OutR2\  
14>CalLoRevI OutR2

---

---

### 7.3.5. Voltage Output Cal Forward

---

---

1. Connect the appropriate load for voltage calibration as determined in section 7.2.3 to the power supply as shown in section 7.3.1. above.
2. Use the **ARROW keys** to select 5>CalHi FwdVOut \ and press **ENTER**.
3. Use the **ARROW keys** to adjust the calibration value until the output voltage on the meter connected across the power supply outputs reads the proper value for 100% of the voltage rating of the supply.

NOTE: Adjusting the calibration value UP will bring the output current UP and vice versa.

4. When the meter reading is correct press the **ENTER** key.

NOTE: The READING calibration value is taken when the **ENTER** key is pressed. Allow at least 1 second after the calibration value is adjusted before pressing the **ENTER** key to allow the output and readback to stabilize.

5. Use the **ARROW keys** to select 6>CalLoFwdVOut \ and press **ENTER**.
6. Use the **ARROW keys** to adjust the calibration value until the output voltage on the meter connected across the power supply outputs reads the proper value for 10% of the voltage rating of the supply.
7. When the meter reading is correct press the **ENTER** key.
8. Repeat steps 2 through 7 as necessary to recheck the calibration.
9. When finished with calibration pressing the **ESC** key will bring up a screen asking if you would like to save the cal table or not. Press **ENTER** to save it or **ESC** to not save the changes that were made during calibration.

---

---

### 7.3.6. Voltage Output Cal Reverse (option)

---

---

If the Reverse Option is installed, the Reverse Voltage Output is calibrated in the same way as Forward by using the **ARROW keys** to select

7>CalHi RevVOut \ and

8>CalLoRevVOut \ menu items.

## 7.4. Analog Calibration (option)

If the optional Analog Control interface is installed in the power supply, follow this procedure to calibrate it. Use a small flat screwdriver (2.5mm or 0.1in) to install wires in the connector.

### 7.4.1. Setup -- 4-20mA, 0-5v or 0-10v Interface

1. Connect the calibrator (Ronan model x86 or equiv.) to the Analog Control connector of the power supply as shown below. The calibrator should be set to a range that will maximize resolution for a 20mA signal on a 4-20mA interface (5v for 0-5v or 10v for 0-10v).
2. Install six jumpers as shown in **Figure 7.2** below. From 3 to 13, 4 to 14, 5 to 15, 6 to 16, 7 to 17 and 8 to 18. The jumpers are required for accurate calibration.
3. With the unit in STANDBY press the **SYS** key.
4. Use the **ARROW** keys to scroll to 5>CalibrateSets/Reads and press **ENTER**.
5. Enter the 4 digit password.
6. Use the **ARROW** keys to select the parameter being calibrated.

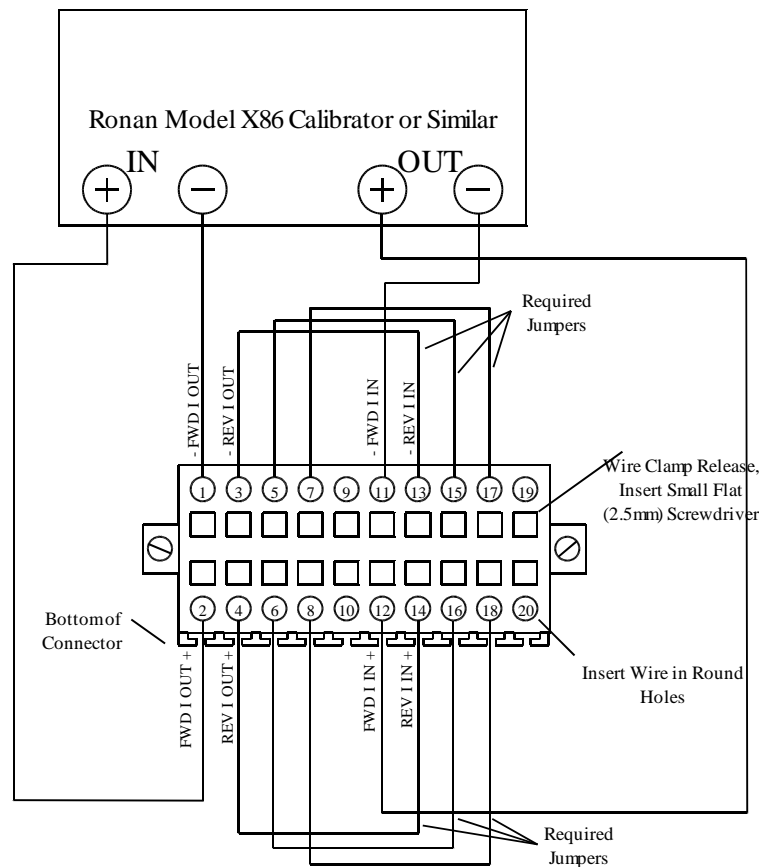

Figure 7.2: Analog Calibration Connections - Forward Current Channel

---

---

## 7.4.2. Analog Channel Calibration

---

---

1. Set the calibrator output to 20mA. (5v for 0-5v or 10v for 0-10v).
2. Use the **ARROW keys** to select 13>CalHi AnlFwdl Out\ and press **ENTER**.
3. Use the **ARROW keys** to adjust the calibration value until the calibrator input reads the proper value for 100% analog control signal, 20mA for 4 20mA interface (5v for 0-5v or 10v for 0-10v).

NOTE: Adjusting the calibration value UP will move the analog output current (or voltage) UP and vice versa.

4. When the calibrator input reading is correct press the **ENTER** key.

NOTE: The Analog Input calibration value is taken when the **ENTER** key is pressed. **Allow at least 3 seconds after the calibration value is adjusted before pressing the ENTER key** to allow the output and readback to stabilize. The analog input is required for proper calibration.

5. Set the calibrator output to 5.6mA for 4-20mA (0.5v for 0-5v or 1v for 0-10v).
6. Use the **ARROW keys** to select 14>CalLoAnlFwdl Out\ and press **ENTER**.
7. Use the **ARROW keys** to adjust the calibration value until the calibrator input reads the proper value for 10% analog control signal, 5.6mA for 4 20mA interface (0.5v for 0-5v or 1v for 0-10v).
8. When the calibrator input reading is correct press the **ENTER** key.
9. Repeat steps 1 through 8 as necessary to recheck the calibration.
10. Repeat steps 1 through 9 for the remaining Analog Control channels. Switch the meter connections to the next set of + and - terminals (i.e. from 1 and 2 to 3 and 4 respectively, and from 11 and 12 to 13 and 14 respectively) that the supply uses for analog control. Also, switch the jumpers (See **Figure 7.3** through **Figure 7.4** below). If the Reverse Option is not installed, skip the reverse terminals and menu items (jumpers are still required).
11. When finished with calibration, pressing the **ESC** key will bring up a screen asking if you would like to save the cal table or not. Press **ENTER** to save or **ESC** to not save the changes that were made during calibration.

NOTE: Saving the calibration table saves the values in RAM to Flash. The changes made during calibration are part of the calibration table in RAM memory and will be lost if not saved when exiting the calibration mode.

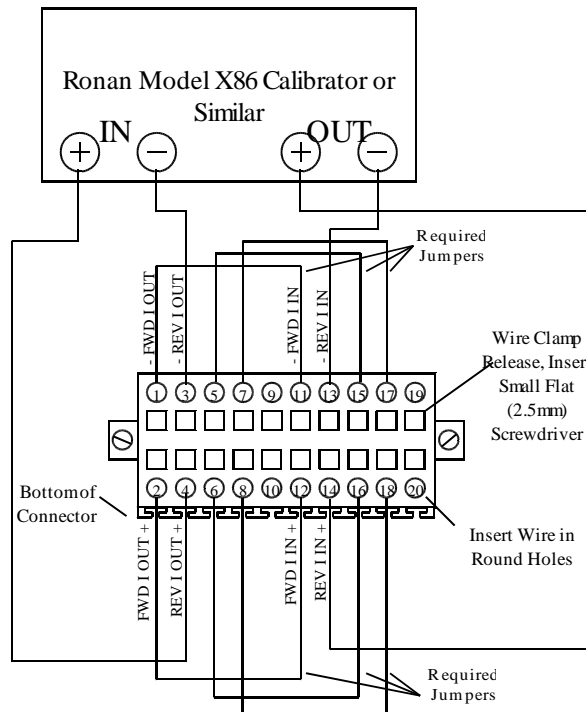

Figure 7.3: Analog Calibration Connections - Reverse Current Channel - (option)

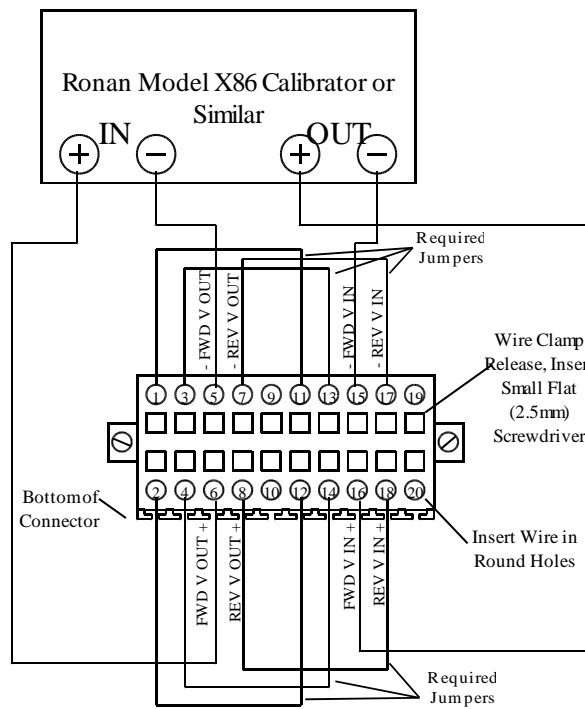

Figure 7.4: Analog Calibration Connections - Forward Voltage Channel

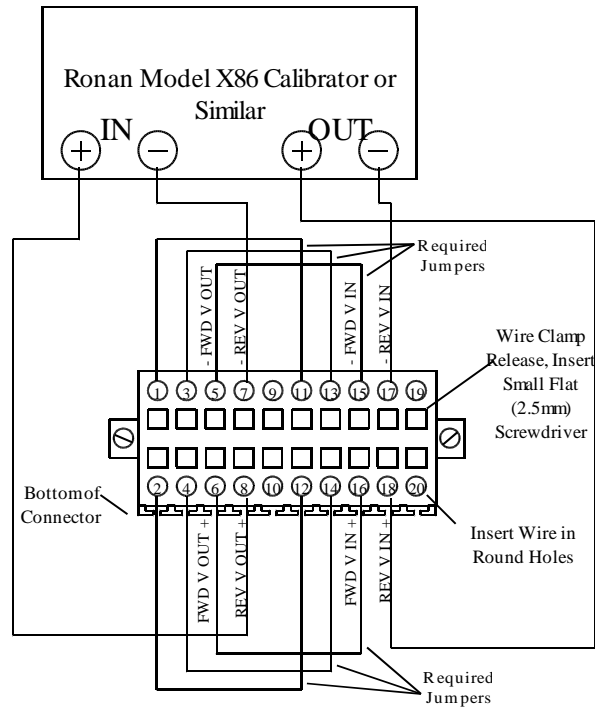

Figure 7.5: Analog Calibration Connections - Reverse Voltage Channel - (option)

---

## 8. Optional Special Features

---

This section describes any special features that are part of the power supply. They are items that go beyond the standard options list.

**No Special Features**



## 9. Spare Parts and Reference Documentation

### 9.1. Spare Parts List

Qty	Description	Dynatronix P/N
1	CCA, MACH2 CONTROLLER, W/HOST & USB	138-0480-XX
1	CCA, MACH2 TERMINAL,W/USB	138-0481-00
2	FUSE, LOGIC, .5ASB	070-0115-00
1	CCA, Output Driver, with Bridge 138-0385-xx	138-0385-xx
1	Diode Block, 35Amp, 600V	022-0178-00
2	115Vac Fuse, 1.25 Amp, 250VAC,slow blow, 1/4x1-1/4	070-0101-00
2	230Vac Fuse, 1 Amp, 250VAC, slow blow, 1/4x1-1/4	070-0221-00
<p>NOTE: Configuration information must be set into the item number 138-0480-XX when replacing a malfunctioning board assembly. Consult the factory when replacing this item. The -XX on the part number will change depending on the unit size and will only work in units of that size. NOTE: The calibration values are also in the 138-0480-XX board so the unit will most likely need calibration when this board is replaced.</p>		

### 9.2. Reference Document List

Description	Dynatronix P/N
Schematic, D $\mu$ P(R)XX Series Overall	131-0711-XX
SCHEMATIC, MACH2 CONTROLLER, W/HOST & USB	231-0480-XX
SCHEMATIC, MACH2 TERMINAL, W/USB	231-0481-XX
SCHEMATIC, MACH-2 ANALOG INTFC,W/IMPRVD TRANSMITTER (option)	231-0362-02
SCHEMATIC, MACH-2 MASTER-SLAVE INTFC (option)	231-0363-10

# A. Menu Flow Chart

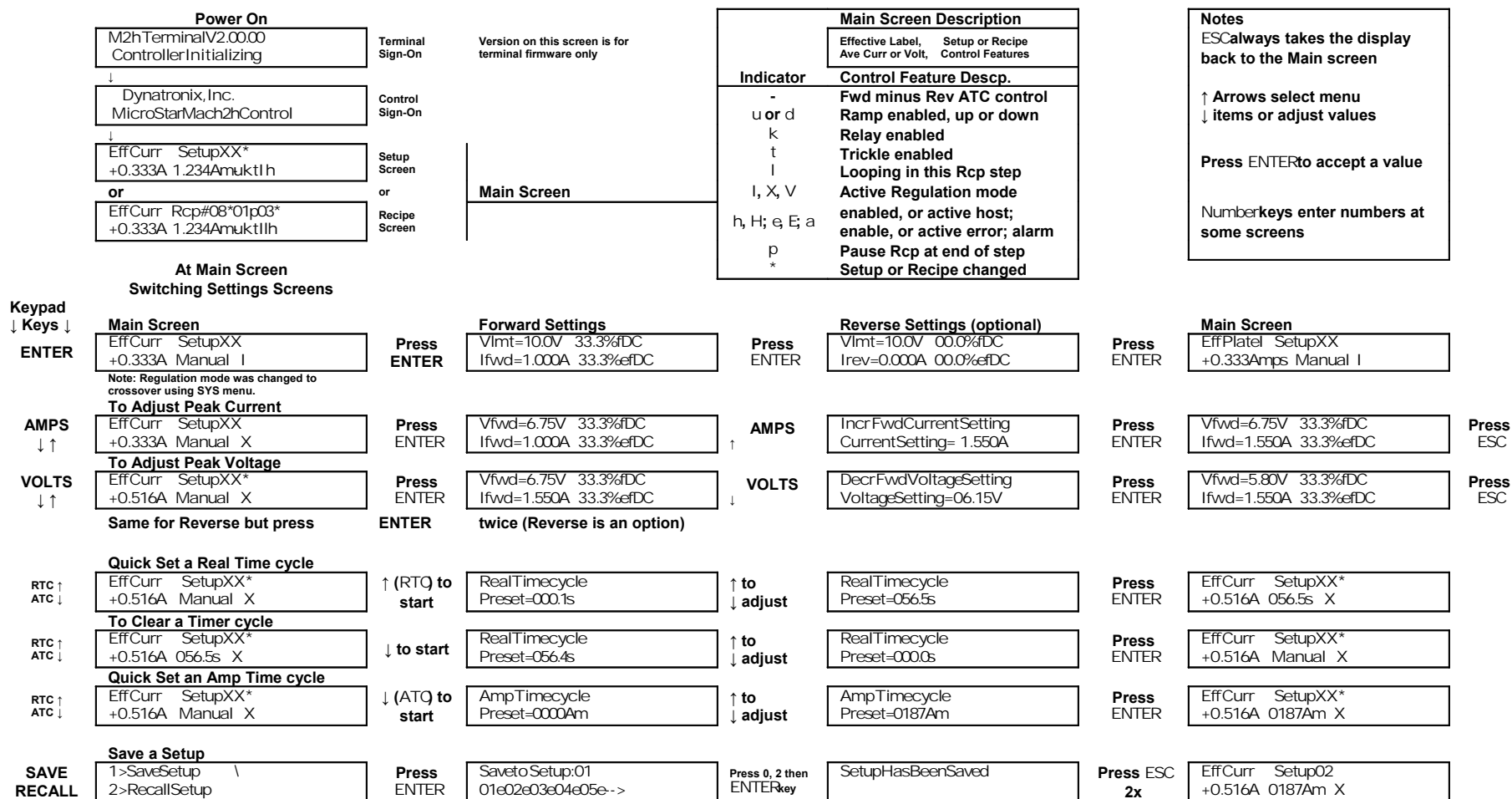

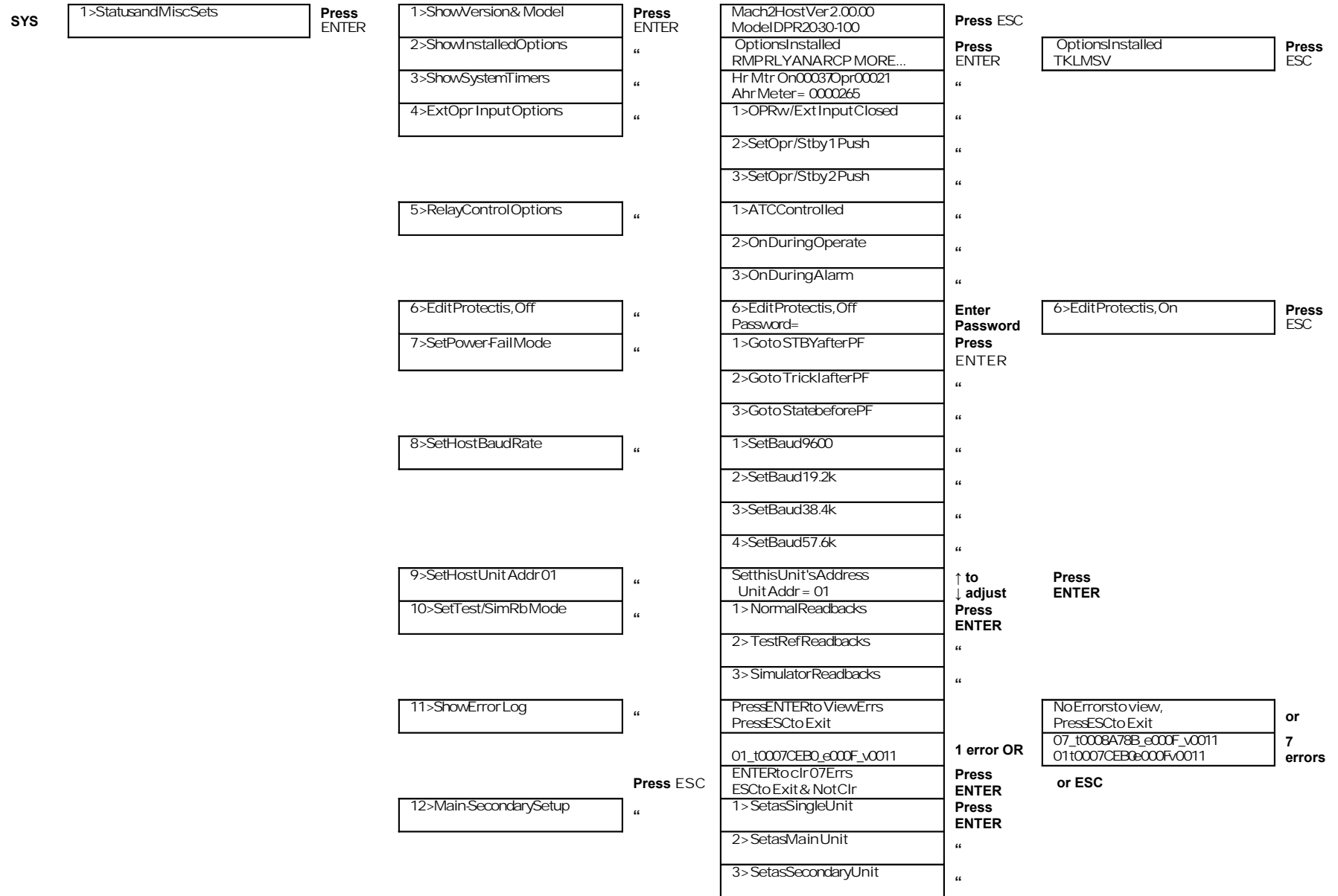

			13>SetDual-RangeMode	“	1>AutoRange	Press ENTER		
					2>HighRange	“		
					3>LowRange	“		
SYS	2>SetRegulationMode	Press ENTER	1>SetCurrentRegMode	Press ENTER	Unit Set To Current Reg Ctol=00% Vtol=00%	Press ENTER		
			2>SetCrssovrRegMode	“	Unit Set To Crssovr Reg Ctol=00% Vtol=00%	“		
			3>SetVoltageRegMode	“	Unit Set To Voltage Reg Ctol=00% Vtol=00%	“		
SYS	3>SetCurr & VoltTol	Press ENTER	1>SetCurr Tol. Window	Press ENTER	Current Tol. %Window Tolerance%=00	↑ to ↓ adjust	<b>NOTE: A setting of 0 (zero) disables Tolerance Checking.</b>	Press ENTER
			2>SetVolt Tol. Window		Voltage Tol. %Window Tolerance%=00	“		“
SYS	4>SetResolutions	Press ENTER	1>SetTotalizerResol.	Press ENTER	1>x.xxxAmin	Press ENTER	x.xxxAminResolution Selected	Press ENTER
					2>xx.xxAmin	“	xx.xxAminResolution Selected	“
					3>xxx.xAmin	“	xxx.xAminResolution Selected	“
					4>xxxxAmin	“	xxxxAminResolution Selected	“
					5>x.xxxAhrs	“	x.xxxAhrsResolution Selected	“
					6>xx.xxAhrs	“	xx.xxAhrsResolution Selected	“
					7>xxx.xAhrs	“	xxx.xAhrsResolution Selected	“
					8>xxxxAhrs	“	xxxxAhrsResolution Selected	“
			2>SetRealTimeResol.	Press ENTER	1>xxx.xSec	Press ENTER	xxx.xSecResolution Selected	Press ENTER
					2>xxxxSec	“	xxxxSecResolution Selected	“
					3>xx.xxMin	“	xx.xxMin Resolution Selected	“
					4>xxx.xMin	“	xxx.xMin Resolution Selected	“
					5>xxxxMin	“	xxxxMin Resolution Selected	“
					6>xx.xxHrs	“	xx.xxHrsResolution Selected	“
					7>xxx.xHrs	“	xxx.xHrsResolution Selected	“

SYS		3>SetAmpTimeResol.	Press ENTER	<table border="1"> <tr><td>1&gt;x.xxxAmin</td><td>Press ENTER</td></tr> <tr><td>2&gt;xx.xxAmin</td><td>"</td></tr> <tr><td>3&gt;xxx.xAmin</td><td>"</td></tr> <tr><td>4&gt;xxxxAmin</td><td>"</td></tr> <tr><td>5&gt;x.xxxAhrs</td><td>"</td></tr> <tr><td>6&gt;xx.xxAhrs</td><td>"</td></tr> <tr><td>7&gt;xxx.xAhrs</td><td>"</td></tr> <tr><td>8&gt;xxxxAhrs</td><td>"</td></tr> </table>	1>x.xxxAmin	Press ENTER	2>xx.xxAmin	"	3>xxx.xAmin	"	4>xxxxAmin	"	5>x.xxxAhrs	"	6>xx.xxAhrs	"	7>xxx.xAhrs	"	8>xxxxAhrs	"	<table border="1"> <tr><td>x.xxxAminResolution Selected</td><td>Press ENTER</td></tr> <tr><td>xx.xxAminResolution Selected</td><td>"</td></tr> <tr><td>xxx.xAminResolution Selected</td><td>"</td></tr> <tr><td>xxxxAminResolution Selected</td><td>"</td></tr> <tr><td>x.xxxAhrsResolution Selected</td><td>"</td></tr> <tr><td>xx.xxAhrsResolution Selected</td><td>"</td></tr> <tr><td>xxx.xAhrsResolution Selected</td><td>"</td></tr> <tr><td>xxxxAhrsResolution Selected</td><td>"</td></tr> </table>	x.xxxAminResolution Selected	Press ENTER	xx.xxAminResolution Selected	"	xxx.xAminResolution Selected	"	xxxxAminResolution Selected	"	x.xxxAhrsResolution Selected	"	xx.xxAhrsResolution Selected	"	xxx.xAhrsResolution Selected	"	xxxxAhrsResolution Selected	"
1>x.xxxAmin	Press ENTER																																				
2>xx.xxAmin	"																																				
3>xxx.xAmin	"																																				
4>xxxxAmin	"																																				
5>x.xxxAhrs	"																																				
6>xx.xxAhrs	"																																				
7>xxx.xAhrs	"																																				
8>xxxxAhrs	"																																				
x.xxxAminResolution Selected	Press ENTER																																				
xx.xxAminResolution Selected	"																																				
xxx.xAminResolution Selected	"																																				
xxxxAminResolution Selected	"																																				
x.xxxAhrsResolution Selected	"																																				
xx.xxAhrsResolution Selected	"																																				
xxx.xAhrsResolution Selected	"																																				
xxxxAhrsResolution Selected	"																																				
SYS	For Pulse Reversing Type Units (DPR, DuPR, CRS-LFPR)	4>SetFwd/RevResolution	Press ENTER	<table border="1"> <tr><td>1&gt;xx.xxmSec</td><td>Press ENTER</td></tr> <tr><td>2&gt;xxx.xmSec</td><td>"</td></tr> <tr><td>3&gt;x.xxxSec</td><td>"</td></tr> <tr><td>4&gt;xx.xxSec</td><td>"</td></tr> </table>	1>xx.xxmSec	Press ENTER	2>xxx.xmSec	"	3>x.xxxSec	"	4>xx.xxSec	"	<table border="1"> <tr><td>x.xxxAminResolution Selected</td><td>Press ENTER</td></tr> <tr><td>xx.xxAminResolution Selected</td><td>"</td></tr> <tr><td>xxx.xAminResolution Selected</td><td>"</td></tr> <tr><td>xxxxAminResolution Selected</td><td>"</td></tr> <tr><td>x.xxxAhrsResolution Selected</td><td>"</td></tr> <tr><td>xx.xxAhrsResolution Selected</td><td>"</td></tr> <tr><td>xxx.xAhrsResolution Selected</td><td>"</td></tr> <tr><td>xxxxAhrsResolution Selected</td><td>"</td></tr> </table>	x.xxxAminResolution Selected	Press ENTER	xx.xxAminResolution Selected	"	xxx.xAminResolution Selected	"	xxxxAminResolution Selected	"	x.xxxAhrsResolution Selected	"	xx.xxAhrsResolution Selected	"	xxx.xAhrsResolution Selected	"	xxxxAhrsResolution Selected	"								
1>xx.xxmSec	Press ENTER																																				
2>xxx.xmSec	"																																				
3>x.xxxSec	"																																				
4>xx.xxSec	"																																				
x.xxxAminResolution Selected	Press ENTER																																				
xx.xxAminResolution Selected	"																																				
xxx.xAminResolution Selected	"																																				
xxxxAminResolution Selected	"																																				
x.xxxAhrsResolution Selected	"																																				
xx.xxAhrsResolution Selected	"																																				
xxx.xAhrsResolution Selected	"																																				
xxxxAhrsResolution Selected	"																																				
	For Reversing only Type Units (CRSR, DCR)	4>SetFwd/RevResolution	Press ENTER	<table border="1"> <tr><td>1&gt;xxxxSec</td><td>Press ENTER</td></tr> <tr><td>2&gt;xxxxMin</td><td>"</td></tr> </table>	1>xxxxSec	Press ENTER	2>xxxxMin	"	<table border="1"> <tr><td>x.xxxAminResolution Selected</td><td>Press ENTER</td></tr> <tr><td>xx.xxAminResolution Selected</td><td>"</td></tr> <tr><td>xxx.xAminResolution Selected</td><td>"</td></tr> <tr><td>xxxxAminResolution Selected</td><td>"</td></tr> <tr><td>x.xxxAhrsResolution Selected</td><td>"</td></tr> <tr><td>xx.xxAhrsResolution Selected</td><td>"</td></tr> <tr><td>xxx.xAhrsResolution Selected</td><td>"</td></tr> <tr><td>xxxxAhrsResolution Selected</td><td>"</td></tr> </table>	x.xxxAminResolution Selected	Press ENTER	xx.xxAminResolution Selected	"	xxx.xAminResolution Selected	"	xxxxAminResolution Selected	"	x.xxxAhrsResolution Selected	"	xx.xxAhrsResolution Selected	"	xxx.xAhrsResolution Selected	"	xxxxAhrsResolution Selected	"												
1>xxxxSec	Press ENTER																																				
2>xxxxMin	"																																				
x.xxxAminResolution Selected	Press ENTER																																				
xx.xxAminResolution Selected	"																																				
xxx.xAminResolution Selected	"																																				
xxxxAminResolution Selected	"																																				
x.xxxAhrsResolution Selected	"																																				
xx.xxAhrsResolution Selected	"																																				
xxx.xAhrsResolution Selected	"																																				
xxxxAhrsResolution Selected	"																																				
	For DC Type Units (CRS, DC)	4>SetFwd/RevResolution	Press ENTER	<table border="1"> <tr><td>OptionNot Installed</td><td>Press ENTER</td></tr> </table>	OptionNot Installed	Press ENTER	<table border="1"> <tr><td>x.xxxAminResolution Selected</td><td>Press ENTER</td></tr> <tr><td>xx.xxAminResolution Selected</td><td>"</td></tr> <tr><td>xxx.xAminResolution Selected</td><td>"</td></tr> <tr><td>xxxxAminResolution Selected</td><td>"</td></tr> <tr><td>x.xxxAhrsResolution Selected</td><td>"</td></tr> <tr><td>xx.xxAhrsResolution Selected</td><td>"</td></tr> <tr><td>xxx.xAhrsResolution Selected</td><td>"</td></tr> <tr><td>xxxxAhrsResolution Selected</td><td>"</td></tr> </table>	x.xxxAminResolution Selected	Press ENTER	xx.xxAminResolution Selected	"	xxx.xAminResolution Selected	"	xxxxAminResolution Selected	"	x.xxxAhrsResolution Selected	"	xx.xxAhrsResolution Selected	"	xxx.xAhrsResolution Selected	"	xxxxAhrsResolution Selected	"														
OptionNot Installed	Press ENTER																																				
x.xxxAminResolution Selected	Press ENTER																																				
xx.xxAminResolution Selected	"																																				
xxx.xAminResolution Selected	"																																				
xxxxAminResolution Selected	"																																				
x.xxxAhrsResolution Selected	"																																				
xx.xxAhrsResolution Selected	"																																				
xxx.xAhrsResolution Selected	"																																				
xxxxAhrsResolution Selected	"																																				
	For Pulse and Pulse Reversing Type Units (DP, DPR, LFP, etc)	5>SetOn/Off Resolution	Press ENTER	<table border="1"> <tr><td>1&gt;xx.xxmSec</td><td>Press ENTER</td></tr> <tr><td>2&gt;xxx.xmSec</td><td>"</td></tr> <tr><td>3&gt;x.xxxSec</td><td>"</td></tr> <tr><td>4&gt;xx.xxSec</td><td>"</td></tr> </table>	1>xx.xxmSec	Press ENTER	2>xxx.xmSec	"	3>x.xxxSec	"	4>xx.xxSec	"	<table border="1"> <tr><td>x.xxxAminResolution Selected</td><td>Press ENTER</td></tr> <tr><td>xx.xxAminResolution Selected</td><td>"</td></tr> <tr><td>xxx.xAminResolution Selected</td><td>"</td></tr> <tr><td>xxxxAminResolution Selected</td><td>"</td></tr> <tr><td>x.xxxAhrsResolution Selected</td><td>"</td></tr> <tr><td>xx.xxAhrsResolution Selected</td><td>"</td></tr> <tr><td>xxx.xAhrsResolution Selected</td><td>"</td></tr> <tr><td>xxxxAhrsResolution Selected</td><td>"</td></tr> </table>	x.xxxAminResolution Selected	Press ENTER	xx.xxAminResolution Selected	"	xxx.xAminResolution Selected	"	xxxxAminResolution Selected	"	x.xxxAhrsResolution Selected	"	xx.xxAhrsResolution Selected	"	xxx.xAhrsResolution Selected	"	xxxxAhrsResolution Selected	"								
1>xx.xxmSec	Press ENTER																																				
2>xxx.xmSec	"																																				
3>x.xxxSec	"																																				
4>xx.xxSec	"																																				
x.xxxAminResolution Selected	Press ENTER																																				
xx.xxAminResolution Selected	"																																				
xxx.xAminResolution Selected	"																																				
xxxxAminResolution Selected	"																																				
x.xxxAhrsResolution Selected	"																																				
xx.xxAhrsResolution Selected	"																																				
xxx.xAhrsResolution Selected	"																																				
xxxxAhrsResolution Selected	"																																				



SYS	For DC & DC Reversing Type Units (CRS, CRSR, DC, DCR)	5>SetOn/Off Resolution	Press ENTER	OptionNot Installed	Press ENTER
		6>SetRampTimeResol.	Press ENTER	1>xxxxSec	Press ENTER
				2>xxxxMin	"
		7>SetCurrentRes.	Press ENTER	1>Normal	Press ENTER
				2>x. 0dp	"
				3>x.x 1 dp	
				4>x.xx2 dp	

SYS	5>CalibrateSets/Reads	Press ENTER	Password=	Enter Password		Press ESC	
			1>CalHi FwdI OutR0	Press ENTER	CalAve.FwdI OutR0 Arrowsto Adjust:05067	↑ to adjust	then ENTER
			2>CalLoFwdI OutR0	"	Cal10%AveFwdI OutR0 Arrowsto Adjust:00507	"	then display goes to Cal menu to do next setting Cal.
			3>CalHi RevI OutR0	"	CalAve.RevI OutR0 Arrowsto Adjust:05067	"	or press ESCto Exit
			4>CalLoRevI OutR0	"	Cal10%AveRevI OutR0 Arrowsto Adjust:00507	"	then asks to "SaveCal Table?"
			5>CalHi FwdV Out	"	Cal100%FwdVoltOut Arrowsto Adjust:15200	"	ENTER= Yes, ESC= No
			6>CalLoFwdV Out	"	Cal10%FwdVoltOut Arrowsto Adjust:01520	"	"
			7>CalHi RevV Out	"	Cal100%RevVoltOut Arrowsto Adjust:15200	"	"
			8>CalLoRevV Out	"	Cal10%RevVoltOut Arrowsto Adjust:01520	"	"
			9>CalHi FwdI OutR1	"	Cal10%AveFwdI OutR1 Arrowsto Adjust:15200	"	"
			10>CalLoFwdI OutR1	"	Cal1%AveFwdI OutR1 Arrowsto Adjust:01520	"	"
			11>CalHi RevI OutR1	Press ENTER	Cal10%AveRevI OutR1 Arrowsto Adjust:15200	↑ to adjust	"
			12>CalLoRevI OutR1	"	Cal1%AveRevI OutR1 Arrowsto Adjust:01520	"	"
			13>CalHi AnI FwdI Out	"	Cal100%AnI FwdI Out Arrowsto Adjust:15200	"	"
			14>CalLoAnI FwdI Out	"	Cal10%AnI FwdI Out Arrowsto Adjust:01520	"	"
			15>CalHi AnI RevI Out	"	Cal100%AnI RevI Out Arrowsto Adjust:15200	"	"
		16>CalLoAnI RevI Out	"	Cal10%AnI RevI Out	"	"	

NOTE: Menu items 3, 4, 7, 8, 11, 12, 15, 16, 19, and 20 are only for used for units with Reverse.

NOTE: Menu items 9 to 12 are only for Dual Range systems.

NOTE: Menu items 13 to 20 are only displayed if the Analog Option is installed

			17>CalHi Anl FwdV Out	“	Arrowsto Adjust:01520	“	“
			18>CalLoAnl FwdV Out	“	Cal100%AnlgFwdV Out	“	“
			19>CalHi Anl RevV Out	“	Arrowsto Adjust:15200	“	“
			20>CalLoAnl RevV Out	“	Cal10%AnlgFwdV Out	“	“
					Arrowsto Adjust:01520	“	“
					Cal100%Anlg RevV Out	“	“
					Arrowsto Adjust:15200	“	“
					Cal10%Anlg RevV Out	“	“
					Arrowsto Adjust:01520	“	“
<b>SYS</b>	6>SetPassword	<b>Press ENTER</b>	Old Password=	<b>Enter Old Password</b>	CorrectPasswordEntered	<b>Enter New Password</b>	<b>Default Password = 0000</b>
					NewPassword=		
<b>SYS</b>	7>SetControlSource	<b>Press ENTER</b>	1>SetPanelCntrlMode	<b>Press ENTER</b>			
			2>SetHostCntrlMode	“			
			3>SetAnalogCntrlMode	“			
			4>SetPanelAnalogMode	“			
			5>SetHostAnalogMode	“			

---

<b>ALARM SILENCE</b>	1>EOC Alarm Disabled	<b>Press ENTER</b>	1>EOC Alarm Enabled	<b>Press ESC</b>
<b>ALARM SILENCE</b>	2>Ierr Alarm Disabled	“	2>Ierr Alarm Enabled	“
<b>ALARM SILENCE</b>	3>Verr Alarm Disabled	“	3>Verr Alarm Enabled	“
<b>ALARM SILENCE</b>	4>Relay Alarm Disabled	“	4>Relay Alarm Enabled	“

---



<b>CYCLE CNTRL</b>	1>SetRealTimeCycle	Press ENTER	RealTimeCycle Preset=000.0s	↑ to ↓ adjust	Press ENTER	Press ESC		
<b>CYCLE CNTRL</b>	2>SetAmpTimeCycle	"	AmpTimeCycle Preset=000.0Am	"	"	"		
<b>CYCLE CNTRL</b>	3>SetRecipeCycle	"	S1 EnterRecipeSetups UsingNumberKeys	Press Numbers 2 digit (ie 0,4)	S01S02S03S04--> 04 05 06 10	Press ESC ESC	EffCurr Rcp#XX*0104* +0.333A 1.234Amuktllh	
<b>CYCLE CNTRL</b>	4>SetRecipeLooping	"	Loop:RunStp010001Times JmpToStep01if > 0001 Loop:RunStp040014Times JmpToStep01if > 0001	→ to <b>Step 4</b> Press <b>Number 3</b>	Loop:RunStp040001Times JmpToStep01if > 0001 Loop:RunStp040014Times JmpToStep03if > 0001	↑ adjust# ↓ Times Press ESC	Loop:RunStp040014Times JmpToStep01if > 0001 Loop:RunStp010001Times JmpToStep01if > 0001	Press ENTER Press ESC
<b>CYCLE CNTRL</b>	5>SetManualCycle	Press ENTER	CycleSetToManual	Press ESC	EffCurr SetupXX* +0.333A Manualuktllh			
<b>CYCLE CNTRL</b>	6>SetRelayTrip Point	"	SetRelayTrip Point Preset=00.00Am	↑ adjust ↓ Times	SetRelayTrip Point Preset=03.60Am	Press ENTER	Press ESC	
<b>CYCLE CNTRL</b>	7>SetRelayOn Time	"	SetRelayOn Time Duration=000.0m	↑ adjust ↓ Times	SetRelayOn Time Duration=001.5m	"	"	
<b>CYCLE CNTRL</b>	8>View Totalizer	Press ENTER	FwdTotal=0924.735Am RevTotal=0000.000Am	Press ESC	NOTE: Reverse Totalizer only shows on Reversing units.			
<b>CYCLE CNTRL</b>	9>Clear Totalizer	"	Password=	Enter Password	CorrectPasswordEntered TotalizerCleared	Press ESC		
<b>CYCLE CNTRL</b>	10>SubtractRevAmpTime	"	ForwardMinusReversais Disabled	Press ENTER	ForwardMinusReversais Enabled	"		

<b>SAVE RECALL</b>	1>SaveSetup	Press <b>ENTER</b> then	SaveTo Setup:01 UseNum.Keys[0-9] SetupHasBeenSaved	Short Delay Press <b>ESC</b>	SaveTo Setup:01 01e02e03e04e05e-->	Press <b>0 &amp; 3</b>	SaveTo Setup:03 01e02e03e04e05e-->	Press <b>ENTER</b>
	<b>Or this if location is used</b>							
	1>SaveSetup	Press <b>ENTER</b> then	SaveTo Setup:01 UseNum.Keys[0-9] OverwriteSetup:03? ENTER= Yes ESC= No	Short Delay Press <b>ENTER</b>	SaveTo Setup:01 01e02e03 04e05e--> SetupHasBeenSaved	Press <b>0 &amp; 3</b> Press <b>ESC</b>	SaveTo Setup:03 01e02e03 04e05e-->	Press <b>ENTER</b>
<b>SAVE RECALL</b>	2>RecallSetup	Press <b>ENTER</b>	RecallFromSetup:03 01e02e03 04e05e-->	Press <b>ENTER</b>	LoadSetup:03? ENTER= Yes ESC= No	and /or	SetupHasBeenRecalled	Press <b>ESC</b>
<b>SAVE RECALL</b>	3>DeleteSetup	"	DeleteSetup:03 01e02e03 04e05e-->	"	DeleteSetup:03? ENTER= Yes ESC= No	"	SetupHasBeenDeleted	"
<b>SAVE RECALL</b>	4>SaveRecipe	Press <b>ENTER</b>	SaveTo Recipe:01 01 02e03e04e05e-->	Press <b>ENTER</b>	OverwriteRecipe:01? ENTER= Yes ESC= No	and /or	RecipeHasBeenSaved	Press <b>ESC</b>
<b>SAVE RECALL</b>	5>RecallRecipe	"	RecallFromRecipe:01 01 02e03e04e05e-->	"	LoadRecipe:01? ENTER= Yes ESC= No	"	RecipeHasBeenRecalled	"
<b>SAVE RECALL</b>	6>DeleteRecipe	"	DeleteFromRecipe:01 01 02e03e04e05e-->	"	DeleteRecipe:01? ENTER= Yes ESC= No	"	RecipeHasBeenDeleted	"

<b>F1</b>	1>SetRampMode	Press <b>ENTER</b>	1>RampDisabled 2>RampUp 3>RampDown	Press <b>ENTER</b> " "				
<b>F1</b>	2>SetRampTime	Press <b>ENTER</b>	RampDuration Duration=0000s	↑ adjust ↓ time	RampDuration Duration=0025s	Press <b>ENTER</b>		
<b>F1</b>	3>SetRampOffset	"	RampOffset Offset%=00	↑ adjust ↓ offset	RampOffset Offset%=05	Press <b>ENTER</b>		
<b>F1</b>	4>SetTrickleLevel	"	TrickleCurrentLevel %of Ifwd= 00%00.00A	↑ adjust ↓ level	TrickleCurrentLevel %of Ifwd= 05%00.55A	Press <b>ENTER</b>		
<b>F1</b>	5>TrickleModeis Off	"	5>TrickleModeis On	Press <b>ESC</b>				

<b>Note: Menu for: DPR, DuPR, DPD, DuPD CRS-LFPR</b>						
TIMING	1->SetFwdOn Time	Press ENTER	Fon=04.00ms	↑ adjust ↓ time	Fon=04.15ms	Press ENTER
	2->SetFwdOff Time	Press ENTER	Foff=02.00ms	↑ adjust ↓ time		Press ENTER
	3->SetForwardDuration	Press ENTER	Fwd=06.00ms	↑ adjust ↓ time		Press ENTER
	4->SetReverseDuration	Press ENTER	Rev=00.00ms	↑ adjust ↓ time		Press ENTER
	5->SetRevOn Time	Press ENTER	Ron=00.00ms	↑ adjust ↓ time		Press ENTER
	6->SetRevOff Time	Press ENTER	Roff=00.00ms	↑ adjust ↓ time		Press ENTER
<b>Note: Menu for DP, DuP, CRS-LFP</b>						
TIMING	1->SetFwdOn Time	Press ENTER	Fon=04.00ms	↑ adjust ↓ time	Fon=04.15ms	Press ENTER
	2->SetFwdOff Time	Press ENTER	Foff=02.00ms	↑ adjust ↓ time		Press ENTER
<b>Note: Menu for DCR and CRSR (units have reversing module but no pulsing)</b>						
TIMING	1->SetForwardDuration	Press ENTER	Fwd=0060s	↑ adjust ↓ time		Press ENTER
	2->SetReverseDuration	Press ENTER	Rev=0012s	↑ adjust ↓ time		Press ENTER
<b>Note: Menu for DC and CRS (units have no pulsing or reversing capability)</b>						
TIMING	EffPlatel SetupXX OptionNotInstalled					

**Optional Main/Secondary Menu**

M/S	1->SendAllM/S Settings	Press ENTER	PressENTERto senddata	Selected data is sent to the secondary(s)
M/S	2->SendAll But Levels		“	Selected data is sent to the secondary(s)
M/S	3->SendTimingOnly		“	Selected data is sent to the secondary(s)

**Optional Recipe Edit Keys (VOLTS and AMPS keys)**

**Highlight = Flashing Cursor**

P/S	S01S02S03--> 01 05 █	Press P/S	S01S02P03--> 01 05 █	Changes pause state from Step (S03) to Pause (P03) and back again	
→	S01S02P03S04S05--> 01 05 06 07 08	Press →	S06S07--> 01 █	Moves to the next page of steps	ALSO: Will step an operating recipe with Manual steps
INS	S01S02S03S04--> 01 05 █ 06 07	Press INS	S01S02S03S04S05--> 01 05 █ 01 06 07	Inserts a step at the cursor	
DEL	S01S02S03S04S05--> 01 05 01 █ 06 07	Press DEL	S01S02S03S04--> 01 05 01 █	Deletes the step at the cursor	

## B. Mach2 Host Protocol

This section describes the Host Protocol for the Mach2 (M2) controlled power supplies that use the 480 control board. These include the DP, DPR, DPD, DuP, DuPR, DuPD, CRS & CRSR w/M2, CRS LFP, CRSR LFP and DC & DCR w/M2 power supplies. The protocol is ASCII text based. Commands can be edited and displayed in a text word processor for testing and troubleshooting purposes. The protocol revision history is at the end of this section.

### B.1. Alphabetical Command Character List

Command Character	Description	Page Link
* (any)	A <b>command response</b> will return the <b>same letter</b> as the command received.	
	<b>ACK</b> - command type 3, either requested data or default ACK command.	124
	<b>NAK</b> - command type 4, due to bad command format or other type of error.	138
a	State command	149
c	CRC Disable/Enable command	135
d	Readings command	140
h	Error History	137
m	Alarm & Error Status command	125
n	Calibration Analog command	129
o	Calibration Output & Meters command	132
r	Recipe command	142
s	Setup command.	145
t	User Settings command	154
u	Unit Values command	151
v	Available Setups command	128
w	Available Recipes command	127

## **B.2. Formatting and Communications Rules**

---

1. ASCII based, no control characters (except CR-LF terminator), only standard alpha-numeric-punctuation characters.
2. Numbers are numeric only (decimal) and can have a decimal point (period).
3. The "@" is the sync char, any @ rx'ed in the middle of a command will cause a NAK error and restart the parser.
4. All data fields are delimited by at least a comma ",". See **B.3. Command Format** below.
  - 4.1. Delimiters can be alpha-numeric-punctuation (not period "." or "@") and require a comma "," at the end.
  - 4.2. Delimiters can have any desired text, except as noted in **4.1.** above, between the field value and the comma but cannot start with a numeric (0-9) value (ie. s6LoopTo, is a valid delimiter).
  - 4.3. Special case delimiters are used to name Setups, Recipes and the Unit. To name a Setup the delimiter in the 'setup number' field would have a ':' (colon) after the setup number and then text for the setup name. There can be up to 19 characters in the name and can be any alpha-numeric character including punctuation (except '@' and ','). For example this command will name setup 2 on unit 01 as GoldFlashRamp\_023ab; @01s1#34,2:GoldFlashRamp\_023ab,... See the Setup, Recipe and User commands for more information.
  - 4.4. Default delimiter text is shown in the second column in the command tables. This text is what the unit will return as a delimiter if enabled with the "i" command. There is no requirement for the host to send delimiter text even if delimiter text is enabled. The host can send delimiter text always if desired whether or not delimiter text is enabled. Do not rely on the delimiter text show as it is subject to change.
5. All command characters are lower case letters (easier to differentiate from numbers, ie. s5 vs S5).
6. Commands can have a variable number of characters. Maximum length is 500 characters.
7. Commands have CRC for error checking value at the end of the command. The CRC is calculated from all the ASCII characters, starting with the sync and ending with the comma before the CRC value. There is no response from a command received when a unit detects a CRC error.
8. Commands are always command/response from host-to-unit-to host (host-response). The host will send a command and the unit will respond with an ACK or NAK command. The ACK will be the requested data or just a normal ACK command. The NAK command is sent if there is some type of error and will contain the error data.
9. Out of range values rx'ed are flagged with a NAK. The whole command is rejected and no values are set. See NAK command.
10. Commands are terminated by carriage return 0x0D and line feed 0x0A (hex values).
11. Any chars between a CR-LF and @ are ignored. These chars will set a 'comm error' bit flag in the NAK or Alarm replies.
12. This protocol is fully text-editor compatible. Commands can be typed into a text editor and then sent to the unit with a terminal program. Commands can also be typed directly into a terminal program to control a unit (just for testing).
13. No scientific notation allowed (i.e. 7.65e2 or 4.56E-1 are not allowed).

14. No signed numbers allowed, sign is inferred as: forward values are positive, reverse values are negative, other values are positive (i.e. -2.54 or +3.75 are not allowed).
15. Maximum number of digits is 7 (i.e. 1234567, 76.54321, 0.765432).
16. The 'no response' time-out duration the host should use in order for the Mach2 controller to have enough time to process commands is dependent on the baud rate and the amount of data.
  - 16.1. The basic response time of the Mach2 controller is 100ms or less.
  - 16.2. At 57.6k baud the host should wait 100ms typically and up to 200ms if the command has 500 characters.
  - 16.3. At 9600 baud the host needs to wait up to 600ms if the command has 500 characters (after complete transfer of the command to the Mach2 unit, so if the host operating system is handling communications to the unit then the total wait time could be as much as 1100ms or more depending on the operating system).
17. Global commands do not return a response from any unit.
18. Any program that uses this protocol would ideally allow all commands to be variable length for future protocol changes. As of protocol version 1.09 the Available Setups, Available Recipes, Error History, Recipe and Readings commands are variable length.

### B.3. Command Format

Example Command: @00e3#2,NN.NNtext1,NNtext2,CRCcrLf

Cmd Field	Delimiter Text	Field Description
@00		Sync character (@) and unit address, 00 = global, 01 to 99 for unit address (always 2 digits).
e3		Command character (e in this example) and Type - 0=read, 1=set, 2=activate, 3=ack, 4=nak
#2,		Number of fields character (#) and number of fields after the comma, excluding CRC
NN.NN,	text1	Command fields (values shown are just for example), optional text delimiter, comma required. The unit returns alphabetical delimiters when they are enabled (a-z, aa-az). See <b>B.14. Delimiter Text Disable/Enable Command</b> below for more information.
NN,	text2	Command fields (values shown are just for example), optional text delimiter, comma required
CRC		CRC value in ASCII decimal, (value shown as 54321 in examples), see <b>B.6. CRC Calculation</b> below. Calculate from all preceding chars including @ and the comma before the CRC. If CRC checking is disabled then the CRC value is not required to be sent by the host and the CRC value is also not returned by a unit.
crLf		Carriage return and Line feed (0x0D 0x0A)



## B.4. Communications Settings – RS485

– See also **B.22. User Settings Command:** below for other baud rates

Baud Rate	Bits	Parity	Stop Bits	Handshake / Flow Cntl
default = 9600	8	none	1	none (it's host-response)

### RS485 Connector Pin-out:

- 1 nc
- 2 nc
- 3 nc
- 4 Data B (normal low, goes high)
- 5 nc
- 6 nc
- 7 nc
- 8 Common
- 9 Data A (normal high, goes low)

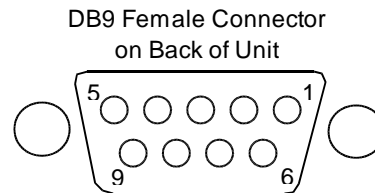

Use a 2-wire RS485 converter or one that is switchable between 2-wire and 4-wire modes.

### Communications Notes:

1. The baud rate can be changed using the User command, see **B.22. User Settings Command:** below for more information, or from the control panel, **6.1.7.3 SYS – System Key**, 1>StatusandMiscSettings, 1>SetHostBaudRate menu.
2. RS485 units can be operated on a multi-drop bus. Each unit on the bus requires a unique address. The Unit Address can be changed using the User command, see **B.22. User Settings Command:** below for more information, or from the control panel, **6.1.7.3 SYS – System Key**, 1>StatusandMiscSettings, 1>SetHostUnitAddr01 menu. The host “master” should always be listening unless sending a command. Secondary units are always listening for commands unless sending a response. Secondary units only respond to commands with their specific address.
3. Units will not respond to a global addressed (00) command.
4. The host must be able to receive all characters in a command without flow control at the set baud rate due to No Handshaking. Potentially up to 512 characters.
5. Nothing is sent out the RS485 port at power-up because the unit is in receiving mode.

NOTE: If you use an RS485 converter that is set up for the Dynatronix PMC series of power supplies then the A and B wires need to be swapped. The MicroStar RS485 wiring is the same as the Dynatronix LT series power supplies.

NOTE: When connecting a unit to a live 485 bus make sure the unit is powered down when the connection is made or errors will occur.

## B.5. Communications Settings – USB

– See also **B.22. User Settings Command:** below for other baud rates

Baud Rate	Bits	Parity	Stop Bits	Handshake / Flow Cntl
default = 9600	8	none	1	none (it's host-response)

### USB Connector:

The USB connector on the back of the unit is a standard USB Type B connector.

### USB Driver:

When using the USB port the host computer requires a USB driver. The most common type is a Virtual Com Port (VCP) driver. This driver is made by Silicon Laboratories (Si Labs) and can be obtained from their site or from Dynatronix Customer Support. The following is a link to Si Labs VCP driver download page.

[www.silabs.com/products/mcu/Pages/USBtoUARTBridgeVCPDrivers.aspx](http://www.silabs.com/products/mcu/Pages/USBtoUARTBridgeVCPDrivers.aspx)

Select the VCP Driver Kit link for the operating system you are using and the driver will start downloading.

Go through the driver installation first and then plug in the USB cable.

The VCP driver allows any program that can open a com port to communicate over a USB port to a Mach2 Host controlled MicroStar power supply.

### Communications Notes:

1. If using the USB port always power up the unit with no communication taking place. The power supply will lock up if the power is applied when the host is sending commands to the unit over the USB port.
2. The baud rate can be changed using the User command, see **B.22. User Settings Command:** below for more information, or from the control panel, **6.1.7.3 SYS – System Key, 1>StatusandMiscSettings, 1>SetHostBaudRate** menu.
3. Units running with the USB port have a single connection bus. Multiple units can be connected to a computer using a USB Hub. The units connected to the computer via the USB port do not require a unique address but it may be a good idea just to keep track of them. The Unit Address can be changed using the User command, see **B.22. User Settings Command:** below for more information, or from the control panel, **6.1.7.3 SYS – System Key, 1>StatusandMiscSettings, 1>SetHostUnitAddr01** menu.
4. Units will not respond to a global addressed (00) command.
5. The host must be able to receive all characters in a command without flow control at the set baud rate due to No Handshaking. Potentially up to 512 characters.
6. The unit dumps the firmware version number, protocol version, the unit serial number, unit name, unit RS485 address and the baud rate out the USB host port when it powers up. This data is always sent at 115.2k baud no matter what the host settings are.
7. Before the data in 6 above is dumped the unit sends an XON character (11 hex) at power-up.
8. USB has a 5 meter / 16 foot maximum cable length unless a USB extender is used.

## B.6. CRC Calculation

---

The CRC is used for error detection. The following is C code for the CRC calculation that Dynatronix uses.

```

////////////////////////////////////
// FUNCTION:    CRC_Calc()
// DESCRIPTION: Get CRC on a string.
// PARAMETERS:  Pointer to string to perform CRC on.
// RETURNS:     CRC word, 00000 to 65535.
// NOTES:       The CRC check used by all Dynatronix stuff.
////////////////////////////////////
uint16_t CRC_Calc (char * szData)
{
    uint16_t    usCRC = 0xFFFF;
    int16_t     sCount = (int16_t)strlen(szData);
    int16_t     sIndex;
    int8_t      cShiftCnt;

    for(sIndex = 0; sIndex < sCount; sIndex ++)
    {
        cShiftCnt = 8;
        usCRC = (uint16_t)(usCRC ^ (szData[sIndex] & 0xFF));
        while (cShiftCnt != 0)
        {
            if ((usCRC & 0x0001) == 0x0001)
            {
                usCRC = (uint16_t)((usCRC >> 1) ^ (uint16_t)0xA001);
            }
            else
            {
                usCRC = (uint16_t)(usCRC >> 1);
            }
            cShiftCnt--;
        }
    }
    return usCRC;
} //CRC_Calc

```

## B.7. ACK Response Command

@00	Sync character and unit address, 00 = global, 01 to 99 is the unit address.
s3	Command character of command received and Command Type - 3=ack
#0,	Number of fields character and number of fields after the comma, excluding CRC
CRC	CRC value in ASCII decimal
crLf	Carriage return and Line feed (0x0D 0x0A)

### Example of ACK Command:

- ACK command for set setup command with no data to return from unit 24  
@24s3#0,54321

### Notes:

1. Sent if no data requested, otherwise the data requested is the ACK (ACKNOWLEDGE).
2. Global commands do not return any response from any units.

## **B.8. Alarm and Error Status Command:**

@00		Sync character and unit address, 00 = global, 01 to 99 is the unit address.
m0		Command character and Type - 0=read, 1=set, 2=activate(n/a), 3=ack, 4=nak
#16,		Number of fields character and number of fields after the comma, excluding CRC
1,	a	'current tolerance' flag - 0=ok, 1=out of tol (not persistent)
1,	b	'current tolerance' audible alarm - 0=ok, 1=out of tol alarm sounding
0,	c	'voltage tolerance' flag - 0=ok, 1=out of tol (not persistent)
0,	d	'voltage tolerance' audible alarm - 0=ok, 1=out of tol alarm sounding
0,	e	'end of cycle' audible alarm - 0=ok, 1=end of cycle alarm sounding. A value of 0 with command type set will silence the eoc alarm.
0,	f	'relay on' audible alarm - 0=ok, 1=relay is on alarm sounding
0,	g	heat sink overtemp flag - 0=ok, 1=overtemp alarm sounding (disables output)
1,	h	bus-bar overtemp flag - 0=ok, 1=overtemp alarm sounding
0,	i	power-fail state - 0=ok, 1=pf standby, 2=pf operate, 3=pf recovered, 4=pf save failure
0,	j	settings defaulted - 0=ok, 1=defaulted due to not being saved properly at power-down (also when unit model or ratings are set, typically at the factory)
0,	k	'interlock open' flag - 0=ok, 1=external interlock is open (not persistent)
1034,	l	communications error bit flags, combined into 1 decimal number - blank or 0=ok, 1=character overrun, 2=command overrun, 4=start over command rx, 8=not a sync char, 10h(16d)=comm interrupt but no char, 20h(32d)=receiver buffer overrun, 40h(64d)=line feed without carriage return at end of command, 80h(128d)=noise error, 100h(256d)=framing error, 200h(512d)=parity error, 400h(1024d)='unknown command' parsing error, 800h(2048d)=CRC error, 1000h(4096d)=global command error.
0,	m	general error number - 0=ok, 1 to 65535 = error number
0,	n	general error value - 0=ok, 1 to 65535 = error value Read the error history command if there are error values in these 2 fields.
0,	o	spare field
0,	p	spare field
CRC		CRC value in ASCII decimal
crlf		Carriage return and Line feed (0x0D 0x0A)

### **Examples of Alarm Status Command:**

- Read alarm status command from unit 1.  
@01m0#0,50998 (correct CRC value shown)

- ACK response for an alarm status command with default text delimiters.  
@01m3#16,0a,0b,0c,0d,0e,0f,0g,0h,0i,0j,0k,0l,0m,0n,0o,p,54321
- ACK response for an alarm status command with comma delimiters.  
@01m3#16,0,0,0,0,0,0,0,0,0,0,0,0,0,0,,54321
- Alarm set command to clear the EOC audible alarm.  
@01m1#16,a,b,c,d,0e,f,g,h,i,j,k,l,m,n,o,p,54321 or @01m1#16,,,,,0,,,,,,,,,,,,,54321

**Notes:**

1. The audible alarms (current tolerance, voltage tolerance, end of cycle, and relay) must be enabled using the Setup command. Also the current and voltage tolerances are set using the Setup command.
2. The audible alarm flags stay active until read, then auto clear unless the alarm source is still active.
3. The current and voltage tolerance flags are non-persistent and can be on for only a short period while a signal is out of tolerance. The tolerance audible alarms are persistent if enabled.
4. The alarms will always set the flag in the Alarm command if that alarm is enabled using the Setup command but will only sound the audible buzzer if the audible buzzer field in the User command is enabled.
5. The power-fail state indicates the recovery state after a brown-out or power-cycle. The User command's Power-Fail Options field determines how the power-fail works. See **B.22. User Settings Command:** below for more information.
6. The relay flag is 1 when the relay is on only for ATC controlled relay output (not opr or alarm controlled relay output, see User command, relay control options). The command to clear the alarm, see note 9. below, will only silence the relay alarm and will not turn off the relay.
7. The communications error flags are cleared when this command is returned (also cleared on any returned NAK)
8. If communications errors persist check communications lines and connections. Contact Dynatronix, Inc. service department if necessary.
9. The audible alarm (on for any reason) can be silenced by sending an Alarm Set command with the 'end of cycle' audible alarm field set to 0, see example above. The audible alarm will come back on if the alarm source is still active.
10. The Alarm command should be read and the CRC Error flag checked whenever there is no response from a command when one is expected. This should be done because a unit will not respond to a command in which it detects a CRC error and the Alarm command is the only way to determine if that was the cause.
11. Report General Error values to Dynatronix Customer Service department.
12. Using an Alarm read command with a global address (00) will clear alarms of all units on a RS485 bus. There will be no response.

## **B.9. Available Recipes Command:**

@00		Sync character and unit address, 00 = global, 01 to 99 is the unit address.
w0		Command character and Type - 0=read, 1=set(n/a), 2=activate(n/a), 3=ack, 4=nak
#9,		Number of fields character and number of fields after the comma, excluding CRC. The (number of fields - 1) will represent the number of Recipes that are available in the unit and is variable depending on unit and features.
8,	a	Number of steps allowed in a recipe (variable depending on unit and features).
0,	b	Recipe 1 availability - 0=used, 1= available / empty
0,	c	Recipe 2 availability - 0=used, 1= available / empty
0,	d	Recipe 3 availability - 0=used, 1= available / empty
0,	e	Recipe 4 availability - 0=used, 1= available / empty
0,	f	Recipe 5 availability - 0=used, 1= available / empty
0,	g	Recipe 6 availability - 0=used, 1= available / empty
0,	h	Recipe 7 availability - 0=used, 1= available / empty
0,	i	Recipe 8 availability - 0=used, 1= available / empty
CRC		CRC value in ASCII decimal.
crLf		Carriage return and Line feed (0x0D 0x0A)

### **Example of Available Recipes Command:**

- Read Available Setups command

@01w0#0,54321

- ACK response for a Read Available Recipes command with 8 recipes and recipe 3 used and delimiter text enabled.

@01w3#9,8a,1b,1c,0d,1e,1f,1g,1h,i,54321

- ACK response for a Read Available Recipes command with 8 recipes and recipe 3 used and delimiters disabled.

@01w3#9,8,1,1,0,1,1,1,1,1,54321

### **Notes:**

1. Use this command to determine how many steps are allowed in a recipe and how many recipes are available in total and which ones have a valid recipe in them.
2. This command is variable length depending on the number of recipes available in the unit.

## B.10. Available Setups Command

@00		Sync character and unit address, 00 = global, 01 to 99 is the unit address.
v0		Command character and Type - 0=read, 1=set(n/a), 2=activate(n/a), 3=ack, 4=nak
#10,		Number of fields character and number of fields after the comma, excluding CRC. The number of fields will represent the number of Setups that are available in the unit and is variable depending on unit and features.
0,	a	Setup 1 availability - 0=used, 1= available / empty
0,	b	Setup 2 availability - 0=used, 1= available / empty
0,	c	Setup 3 availability - 0=used, 1= available / empty
0,	d	Setup 4 availability - 0=used, 1= available / empty
0,	e	Setup 5 availability - 0=used, 1= available / empty
0,	f	Setup 6 availability - 0=used, 1= available / empty
0,	g	Setup 7 availability - 0=used, 1= available / empty
0,	h	Setup 8 availability - 0=used, 1= available / empty
0,	i	Setup 9 availability - 0=used, 1= available / empty
0,	j	Setup 10 availability - 0=used, 1= available / empty
CRC		CRC value in ASCII decimal.
crlf		Carriage return and Line feed (0x0D 0x0A)

### Example of Available Setups Command:

- Read Available Setups command.

@01v0#0,54321

- ACK response for a Read Available Setups command with 8 setups and setup 3 used and delimiter text enabled.

@01v3#10,1a,1b,0c,1d,1e,1f,1g,1h,0i,0j,54321

- ACK response for a Read Available Setups command with 10 setups and setup 3 used and delimiters disabled.

@01v3#10,1,1,0,1,1,1,1,1,1, 54321

### Notes:

1. Use this command to determine how many setups are available in total and which ones are blank and which have a valid setup in them.
2. This command is variable length depending on the number of recipes available in the unit.



## **B.11. Calibration Analog Command:**

@00		Sync character and unit address, 00 = global, 01 to 99 is the unit address.
n0		Command character and Type - 0=read, 1=set (one or more calibration values in RAM), 2=activate (save calibration values to Flash), 3=ack, 4=nak
#16,		Number of fields character and number of fields after the comma, excluding CRC
0,	a	forward current analog output 100% cal point value
0,	b	forward current analog output 10% cal point value
0,	c	forward current analog input 100% cal point value
0,	d	forward current analog input 10% cal point value
0,	e	forward voltage analog output 100% cal point value
0,	f	forward voltage analog output 10% cal point value
0,	g	forward voltage analog input 100% cal point value
0,	h	forward voltage analog input 10% cal point value
0,	i	reverse current analog output 100% cal point value
0,	j	reverse current analog output 10% cal point value
0,	k	reverse current analog input 100% cal point value
0,	l	reverse current analog input 10% cal point value
0,	m	reverse voltage analog output 100% cal point value
0,	n	reverse voltage analog output 10% cal point value
0,	o	reverse voltage analog input 100% cal point value
0,	p	reverse voltage analog input 10% cal point value
CRC		CRC value in ASCII decimal
crlf		Carriage return and Line feed (0x0D 0x0A)

### **Examples of Analog Calibration Command:**

- read analog calibration values command from unit 1.

@01n0#0,51058 (correct CRC value shown)

- ACK response for a read analog calibration values command with default text delimiters with cal table defaulted.

@01nc3#16,15200a,1520b,1520c,1520d,1520e,1520f,1520g,1520h,1520i,1520j,1520k,1520l,1520m,1520n,1520o,1520p, 54321

- ACK response for a read analog calibration values command with comma delimiters with cal table defaulted.

```
@01n3#16,15200,1520,15200,1520,15200,1520,15200,1520,15200,1520,15200,1520,15200,1520,54321
```

- default analog calibration values command for unit 1 (also saves the defaults to flash).

```
@01n1#0,15219 (correct CRC value shown)
```

- set forward voltage 10% setting calibration values command for unit 1.

```
@01n1#24,,,,,,1480,,,,,,,,,,,,,54321
```

- save calibration values to flash command for unit 1.

```
@01n2#0,32627 (correct CRC value shown)
```

### Notes:

1. Analog calibration values control the analog control module settings and readings accuracy for the unit.
2. Defaulting the calibration table automatically saves the defaults to flash.
3. Calibration can be done on the unit using the control panel or with this command as described below.
4. Calibration values can be set using this command. Follow this basic procedure to calibrate the analog channels. The analog card is calibrated using a 4-20mA, 0-5V or 0-10V calibrator. NOTE: This procedure would normally be done by programming a computer to automatically perform the steps with the computer sending the control and calibration commands to the unit and sending calibration levels to and getting readings from the calibrator.
  - 4.1. Attach a calibrator to the forward current in/out as shown in the manual's analog calibration section.
  - 4.2. Set the calibrator output to the 100% setting (20mA, 5V or 10V).
  - 4.3. Send the Analog Calibration command with only a "forward current analog output 100%" calibration value (about 15200).
  - 4.4. Check the input reading on the calibrator.
  - 4.5. Keep adjusting the calibration value until the calibrator input reading is at the 100% value (20mA, 5V or 10V).
  - 4.6. Send an Analog Calibration command with only a "forward current analog input 100%" value set to Zero (0), this will do an auto-cal of the input setting from the calibrator.
  - 4.7. The forward current analog output and input 100% calibration is now done.
  - 4.8. Set the calibrator output to the 10% setting (5.6mA, 0.5V or 1.0V).
  - 4.9. Send the Analog Calibration command with only a "forward current analog output 10%" calibration value (about 1520).
  - 4.10. Check the input reading on the calibrator.
  - 4.11. Keep adjusting the calibration value until the calibrator input reading is at the 10% value (5.6mA, 0.5V or 1.0V).
  - 4.12. Send an Analog Calibration command with only a "forward current analog input 10%" value set to Zero (0), this will do an auto-cal of the input setting from the

calibrator.

4.13. The forward current analog output and input 10% calibration is now done.

4.14. Repeat steps **4.1.** through **4.13.** for each of the output/input signals (forward voltage, reverse current, reverse voltage). NOTE: Only the signals being used by the unit need to be calibrated, if the unit is a DP (no reverse) then the reverse signals do not need to be calibrated. If only voltage regulation mode is being used then the current inputs do not need to be calibrated.

5. Use the activate command to save the calibration values to flash, see example above. Use this command sparingly because it writes to flash each time and flash has a limited lifetime of about 10,000 writes.

## **B.12. Calibration Output & Meters Command:**

@00		Sync character and unit address, 00 = global, 01 to 99 is the unit address.
o0		Command character and Type - 0=read, 1=set (one or more calibration values in RAM), 2=activate (save calibration values to Flash), 3=ack, 4=nak
#24,		Number of fields character and number of fields after the comma, excluding CRC
0,	a	forward current setting 100% cal point value, range 0
0,	b	forward current setting 10% cal point value, range 0
0,	c	forward current reading 100% cal point value, range 0
0,	d	forward current reading 10% cal point value, range 0
0,	e	forward voltage setting 100% cal point value, range 0
0,	f	forward voltage setting 10% cal point value, range 0
0,	g	forward voltage reading 100% cal point value, range 0
0,	h	forward voltage reading 10% cal point value, range 0
0,	i	reverse current setting 100% cal point value, range 0
0,	j	reverse current setting 10% cal point value, range 0
0,	k	reverse current reading 100% cal point value, range 0
0,	l	reverse current reading 10% cal point value, range 0
0,	m	reverse voltage setting 100% cal point value, range 0
0,	n	reverse voltage setting 10% cal point value, range 0
0,	o	reverse voltage reading 100% cal point value, range 0
0,	p	reverse voltage reading 10% cal point value, range 0
0,	q	forward current setting 100% cal point value, range 1
0,	r	forward current setting 10% cal point value, range 1
0,	s	forward current reading 100% cal point value, range 1
0,	t	forward current reading 10% cal point value, range 1
0,	u	reverse current setting 100% cal point value, range 1
0,	v	reverse current setting 10% cal point value, range 1
0,	w	reverse current reading 100% cal point value, range 1
0,	x	reverse current reading 10% cal point value, range 1
CRC		CRC value in ASCII decimal
crLf		Carriage return and Line feed (0x0D 0x0A)

**Output Calibration Command: (cont.)****Examples of Output Calibration Command:**

- read calibration values command from unit 1.

@01o0#0,1871 (correct CRC value shown)

- ACK response for a read calibration values command with default text delimiters for a DPR10-1-3 with cal table defaulted.

@01o3#24,5067a,507b,5067c,507d,15200e,1520f,15200g,1520h,5067i,507j,5067k,507l,15200m,1520n,15200o,1520p,15200q,1520r,15200s,1520t,15200u,1520v,15200w,1520x,54321

- default calibration values command for unit 1 (also saves the defaults to flash).

@01o1#0,64334 (correct CRC value shown)

- set forward voltage 10% setting calibration values command for unit 1.

@01o1#24,,,,,,1480,,,,,,,,,,,,,,,,,,,,,54321

- save calibration values to flash command for unit 1.

@01o2#0,48974 (correct CRC value shown)

**Notes:**

1. Output calibration values control the actual output and meter reading accuracy of the unit.
2. Defaulting the calibration table automatically saves the defaults to flash.
3. Calibration can be done on the unit using the control panel or with this command as described below.
4. Calibration values can be set using this command. When calibrating using this command the host/calibration program must control the settings and operate state of the unit and check readings to get proper calibration. Follow this basic procedure to calibrate the power supply output and readings. The output is calibrated using a load, a calibrated shunt and 1 or 2 precision volt meters. NOTE: This procedure would normally be done by programming a computer to automatically perform the steps with the computer sending the control and calibration commands to the unit and getting readings from the meter(s) for comparison.
  - 4.1. Attach a load, shunt and meter to the output of the power supply as shown in the manual's output calibration section.
  - 4.2. Set the output of the power supply to the average current rating of a pulsed unit or the current rating of a DC unit using the Setup command (i.e. for a DPR20-250-400 use 250A, for a CRS12-50 use 50A).
  - 4.3. Turn the output of the power supply on using the State command.
  - 4.4. Send the Output Calibration command with only a "forward current setting 100%" calibration value set to the proper value (about = ave curr rating \* 15200 / peak curr rating (for a DPR20-250-400 it would be about  $250 * 15200 / 400 = 2500$ ) (for DC units use about 15200)).
  - 4.5. Check the current level by reading the meter attached to the shunt.
  - 4.6. Keep adjusting the calibration value until the shunt meter reading is at the voltage that corresponds to the setting commanded in step b.

- 4.7. Send an Output Calibration command with only a "forward current reading 100%" value set to Zero (0) (all other fields MUST be blank), this will do a check of the 100% current level to calibrate the unit's meter.
  - 4.8. Turn off the output using the State command.
  - 4.9. The forward current output and input 100% calibration is now done.
  - 4.10. Set the output of the power supply to 10% of the average current rating of a pulsed unit or to 10% of the current rating of a DC unit using the Setup command(i.e. for a DPR20-250-400 use 25A, for a CRS12-50 use 5A).
  - 4.11. Turn the output of the power supply on using the State command.
  - 4.12. Send the Output Calibration command with only a "forward current setting 10%" calibration value set to the proper value (about = ave curr rating \* 1520 / peak curr rating (for a DPR20-250-400 it would be about 250 \* 1520 / 400 = 250) (for DC units use about 1520)).
  - 4.13. Check the current level by reading the meter attached to the shunt.
  - 4.14. Keep adjusting the calibration value until the shunt meter reading is at the voltage that corresponds to the setting commanded in step j.
  - 4.15. Send an Output Calibration command with only a "forward current reading 10%" value set to Zero (0) (all other fields MUST be blank), this will do a check of the current level to calibrate the unit's meter.
  - 4.16. The forward current output and input 10% calibration is now done.
  - 4.17. Turn off the output using the State command.
  - 4.18. Repeat steps **4.1.** through **4.17.** for each of the output levels (forward voltage, reverse current, reverse voltage) changing the settings as required. NOTE: Only the signals being used by the unit need to be calibrated, if the unit is a DP (no reverse) then the reverse signals do not need to be calibrated. Be sure to change the load and meter to get the proper output for each level as described in the output calibration section of the manual.
5. Use the activate command to save the calibration values to flash, see example above. Use this command sparingly because it writes to flash each time and flash has a limited lifetime of about 10,000 writes.

## B.13. CRC Disable/Enable Command

@00	Sync character and unit address, 00 = global, 01 to 99 is the unit address.
c1	Command character and Type - 0=read, 1=set, 2=activate(n/a), 3=ack, 4=nak
#1,	Number of fields character and number of fields after the comma, excluding CRC
0, a	CRC flag - 0=disable, 1=enable. Default on power supply power-up is Enabled.
CRC	CRC value in ASCII decimal. NOTE: examples show actual CRC values.
crLf	Carriage return and Line feed (0x0D 0x0A)

### Example of CRC Enable/Disable Command:

- Disable CRC command

@00c1#1,0,52845 (correct CRC value shown)

- Enable CRC command

@00c1#1,1,24172 (correct CRC value shown)

- Read CRC State command. NOTE: make sure address is correct if multiple units.

@00c0#0,55134 (correct CRC value shown for global address 00)

- ACK response for a Read CRC State command from unit with address = 01, with CRC enabled. With and without delimiter text enabled.

@01c3#1,1a,61508

@01c3#1,1,28844

- ACK response for a Read CRC State command from unit with address = 01, with CRC disabled. Note that no CRC is sent.

@01c3#1,0,

### Notes:

1. Default CRC setting on power supply power-up is Enabled.
2. If CRC checking is disabled then the CRC value is not required.
3. When the CRC is disabled the unit does not send any CRC value at the end of a reply.
4. Whenever a CRC error is detected by a unit, that unit will not respond to the command.

## B.14. Delimiter Text Disable/Enable Command

@00	Sync character and unit address, 00 = global, 01 to 99 is the unit address.
i0	Command character and Type - 0=read, 1=set, 2=activate(n/a), 3=ack, 4=nak
#1,	Number of fields character and number of fields after the comma, excluding CRC
0, a	delimiter text flag - 0=disable, 1=enable. Default on power-up is disabled.
CRC	CRC value in ASCII decimal. NOTE: examples show actual CRC values.
crlf	Carriage return and Line feed (0x0D 0x0A)

### Example of Delimiter Text Enable/Disable Command:

- Disable delimiter text command (global for all units on the bus)

@00i1#1,0,52935 (correct CRC value shown)

- Enable delimiter text command (global for all units on the bus)

@00i1#1,1,24262 (correct CRC value shown)

- Read delimiter text State command from unit 01.

@01i0#0,1991 (correct CRC value shown)

- ACK response for a read delimiter text state command, unit address = 12, delimiter text enabled and disabled.

@12i3#1,1a,47745

@12i3#1,1,62795

### Notes:

1. Default Delimiter Text setting on power supply power-up is Disabled.
2. The default delimiter text is what is sent by the secondary unit if delimiter text is enabled. There is no requirement for the host to send delimiter text if delimiter text is enabled, it is optional.
3. The host can chose to send delimiter text whether or not delimiter text is enabled.
4. The delimiter text sent by the unit is subject to change without notice. Do not rely on the text to stay the same.



## B.15. Error History Command

@00		Sync character and unit address, 00 = global, 01 to 99 is the unit address.
h0		Command character and Type - 0=read, 1=set, 2=activate(n/a), 3=ack, 4=nak
#1,		Number of fields character and number of fields after the comma, excluding CRC
1,	a	Number of errors that follow. There are 3 fields per error; error time, error number and error value.
2734,	b	Error Time Stamp, in seconds. This is the unit hour meter timer value. Value is an unsigned 32 bit size (0 to 4,294,967,295).
21,	c	Error Number. Contact Dynatronix Customer Service for more information. Value is unsigned 16 bit size (0 to 65,535).
15,	d	Error Value. Value that indicates what may be wrong. Value is unsigned 16 bit size (0 to 65,535).
...		The error history command is variable length depending on the number of errors that have been logged.
CRC		CRC value in ASCII decimal. NOTE: examples show actual CRC values.
crLf		Carriage return and Line feed (0x0D 0x0A)

### Example of Delimiter Text Enable/Disable Command:

- Read Error History command from unit 01.

@01h0#0,51194 (correct CRC value shown)

- ACK response for a read error history command with 2 errors and delimiter text turned on.

@12h3#7,2a,2743b,21c,15d,2745e,34f,18g,54321

- Clear Error History command for unit 01. Use the "set" command type to clear the error history.

@01h1#0,15355 (correct CRC value shown)

### Notes:

1. Error History command reports any errors that have been logged by the system. These are typically low level hardware or communications errors.
2. It will return a value of #1,0, if there are no errors to report.

## **B.16. NAK Response Command**

Sent when an error occurs in parsing a command

@00		Sync character and unit address, 00 = global, 01 to 99 is the unit address.
s4		Command character of command received and Command Type - 4=NAK
#15,		Number of fields character and number of fields after the comma, excluding CRC
1034,	a	communications error bit flags, combined into 1 decimal number - blank or 0=ok, 1=character overrun, 2=command overrun, 4=start over command rx, 8=not a sync char, 10h(16d)=comm interrupt but no char, 20h(32d)=receiver buffer overrun, 40h(64d)=line feed without carriage return at end of command, 80h(128d)=noise error, 100h(256d)=framing error, 200h(512d)=parity error, 400h(1024d)='unknown command' parsing error, 800h(2048d)=CRC error, 1000h(4096d)=global command error.
0,	b	spare field
0,	c	spare field
0,	d	cannot process command type - not; read, set or activate.
0,	e	wrong number of fields - blank or 0=ok, 1=error
0,	f	bad field number - first field to be found bad - blank or 0=ok, 1 to XX = field number
0,	g	bad field value - bad value, 65534=blank field
0,	h	settings error - blank or 0=ok, 1=i limit: fwd >100ms, 2=i limit: rev >100ms, 3=i limit: sum of fwd & rev > ave, 4=i limit: vreg mode, 5=invalid timing, 6=direction duty cycle current limit. See Note 1. below.
0,	i	option not installed error - blank or 0=ok, 1=ramp, 2=relay, 3=analog, 4=recipe, 5=trickle, 6=main-secondary
0,	j	cannot operate - blank or 0=ok, 1-8=recipe step that is bad, 51=invalid timing, 52=interlock open, 53=analog control.
0,	k	edit protect flag is enabled - blank or 0=ok, 1=protected
0,	l	flash write error - command field number being written, or 100=setup, 101=recipe (Note that a setup or recipe will not activate if there is an error).
0,	m	flash write error - error number
0,	n	host control mode required - see <b>B.22. User Settings Command:</b> , set control mode field
0,	o	another nak'able flag
CRC		CRC value in ASCII decimal
crLf		Carriage return and Line feed (0x0D 0x0A)

**NAK Command: (cont.)****Example of NAK Command:**

- NAK'd setup command with a field error returning field number and value from unit 10 with text delimiters

```
@10s4#15,0a,0b,0c,0d,0e,3f,12.55g,0h,0i,0j,0k,0l,0m,0n,o,54321
```

- NAK'd setup command with host mode required error from unit 10 with only comma delimiters

```
@10s4#15,0,,,,,,,,,,,,,1,,54321
```

**Notes:**

1. For pulsing units, current limiting occurs when settings go beyond the average current rating of the unit. See section **6.7 Messages**, and also section **C Pulse Mathematics** in the power supply manual. The following are descriptions of the types of settings errors

1.1. 'i limit: fwd >100ms' is a current limit error due to the forward pulse timing causing an on time that is greater than 100 milliseconds. Pulsed power supplies cannot have a pulse time greater than 100ms if the current is greater than the average current rating of the unit. One or the other will have to be reduced.

1.2. 'i limit: rev >100ms' is the same as 1.1 but for reverse settings on pulse reverse units.

1.3. 'i limit: sum of fwd & rev > ave' error is caused when the sum of the average forward current plus the sum of the average reverse current is greater than the unit's average current rating.

1.4. 'i limit: vreg mode' is voltage regulation mode current limit. This error is not sent as of protocol version 1.05. The current is automatically adjusted to limit the average current of the output to the average current rating of the unit. The adjusted peak current setting for voltage regulation mode can be read back by reading the active settings using the Setup command.

1.5. '5=invalid timing' is an error returned when the timing settings are not valid. This could be due to one of the parameters being zero when it needs a non-zero value.

1.6. '6=direction duty cycle current limit' shows when the current setting on a pulsing unit is greater than average and the on time pulse duration is greater than 100ms. When the pulse duration is >100ms the current is limited to the average value.

2. The comm error flags are cleared after NAK data is loaded to send (also cleared when an Alarm command is ACKed).

3. The Host must not send a NAK if it gets a bad response. The Host should flag it as a communications error or firmware version issue.

4. Whenever a CRC error is detected by a unit, that unit will not respond to the command (no NAK). When this occurs the alarm flag will be set in the readings command and then the alarm command can be read and the CRC flag should be set.

## B.17. Readings Command:

@00		Sync character and unit address, 00 = global, 01 to 99 is the unit address.
d0		Command character and Type - 0=read, 1=set, 2=activate(n/a), 3=ack, 4=nak
#20 or more,		Number of fields character and number of fields after the comma, excluding CRC. This command is variable length, see Note 3. below.
1,	a	operate state - 0=standby, 1=operate, 2=pause, 3=inhibit, 4=trickle, 5=pause-trickle
1,	b	active setup number - 0-10, 0=unsaved values
2,	c	active recipe number - 0-8, 0=unsaved values
3,	d	active recipe step - 1-8
0.234,	e	forward current - amps, average
1.23,	f	forward voltage - volts, average
0.210,	g	reverse current - amps, average
2.10,	h	reverse voltage - volts, average
1,	i	XTC mode - 0>manual, 1=ATC, 2=RTC (XTC means either ATC or RTC).
9.56,	j	XTC reading - Amin/Ahr for ATC or Sec/Min/Hr for RTC, resolution units determined by RTC & ATC resolution index in Setup command (XTC means either ATC or RTC).
256.1024,	k	forward totalizer - Amin/Ahr, in resolution units of totalizer resolution index in Setup command. To reset the totalizer see Note 5. below.
21.12345,	l	reverse totalizer - Amin/Ahr, in resolution units of totalizer resolution index in Setup command. To reset the totalizer see Note 5. below.
15.5,	m	ramp time reading - Sec/Min, in resolution units of ramp time resolution index in Setup command.
10,	n	forward ramp active level setting - peak amps/volts, depending on regulation mode, see Note 2..
30,	o	reverse ramp active level setting - peak amps/volts, depending on regulation mode, see Note 2..
2.1,	p	relay atc left - Amin/Ahr, in resolution units of totalizer resolution index in Setup command.
10,	q	relay on time left - minutes, xxx.x resolution, non-zero value = relay on
0,	r	alarm flag - 1=read the Alarm command to determine which alarm or error
0,	s	active setup changed flag - blank or 0 = no change, 1 = changed
0,	t	active recipe changed flag - blank or 0 = no change, 1 = changed
1,	u	optional - recipe step 1's 'step run count'. See Notes 3. & 4. below.

1, ...	optional - recipe step n's 'step run count', up to as many steps in the recipe
CRC	CRC value in ASCII decimal
crLf	Carriage return and Line feed (0x0D 0x0A)

### Examples of Readings Command:

- Read readings command.

@01d0#0,50922 (correct CRC value shown)

- ACK response to a readings command with default text delimiters. No recipe enabled

@01d3#20,1a,1b,2c,3d,0.234e,1.23f,0.210g,2.10h,1i,9.56j,256.1024k,21.12345l,15.5m,10n,30o,2.1p,10q,0r,0s,0t,54321

- ACK response to a readings command with only comma delimiters, with no recipe enabled.

@01d3#20,1,1,2,3,0.234,1.23,0.210,2.10,1,9.56,256.1024,21.12345,15.5,10,30,2.1,10,0,0,0,54321

- ACK response to a readings forward only dc unit reading. Blank or zeros in fields that do not apply to the model type. No recipe enabled

@01d3#20,1a,1b,2c,3d,0.234e,1.23f,0g,0h,1i,9.56j,256.1024k,0l,15.5m,10n,0o,2.1p,10q,0r,0s,0t,54321

- ACK response to a readings command with recipe enabled, 5 steps with looping on steps 2 and 5.

@01d3#20,1a,1b,2c,3d,0.234e,1.23f,0.210g,2.10h,1i,9.56j,256.1024k,21.12345l,15.5m,10n,30o,2.1p,10q,0r,0s,0t,1u,3v,1w,1x,24y,54321

### Notes:

1. Current and Voltage resolution returned may have more digits but has the same accuracy as the meters with respect to the unit's specifications: up to 4 digits for current, 3 digits for voltage.
2. When ramping is enabled, current is ramped when either current or cross-over regulation is active. Voltage is ramped in voltage regulation mode.
3. This command is variable length when the recipe mode is active. The length is determined by the number of steps in the recipe (20 + 'number of steps in the recipe'). The basic command is the same length (20) but if a recipe is active there is an extra field for each step in the recipe. The extra fields contain count down of the 'number of times to run the step' value for looping. There will be only 20 fields if the recipe mode is not active.
4. When the optional recipe mode is active and the recipe has looping, the 'step run count' will count down from the preset 'step run # times' to 1 which is the last count. When the count reaches 1 and that step is done the count is reset to the preset value.
5. The forward and reverse totalizers can be reset to 0. To do that, send a 'Reading set' type command with a 0 in the field to reset totalizer to 0. Those are the only 2 parameters that are used in the 'set' command, all others are ignored. The fwd and rev totalizers can also be preset to any value from 0.000001 to 9999999.0

### B.18. Recipe Command:

@00		Sync character and unit address, 00 = global, 01 to 99 is the unit address.
r1		Command character and Type - 0=read, 1=set, 2=activate, 3=ack, 4=nak
#1 or more,		Number of fields character and number of fields after the comma, excluding CRC. This command is variable length depending on how many steps are in the recipe. Only fields with steps used need to be sent or are in a reply.
1, or 1:Name,	a	recipe number - 0=active, 1-8=saved recipe name - optional, name the recipe "TestRcp01" like this ,1:TestRcp01, See Note 13..
		NOTE - none of the following step values need to be sent if only activating a recipe that is already in memory or when reading a recipe
4,	b	step 1 setup number - setup # to run during this step, (1-10).
1,	c	step 1 loop to step # - step number to jump to after this step, if the decremented 'step run count' is > 0. Step number range is (1-8) but can only jump to the same or preceding steps
1,	d	step 1 'step run # times' - number of times to execute this step, (1-9999), before moving to the next step. A value of 1 will run the step once and go to the next step (no looping)
0,	e	step 1 pause flag - 0 = no pause, 1 = pause at end of this step
		NOTE - the following would be for more step values
5,	f	step n's setup number - next step
1,	g	step n's loop to step number
1,	h	step n's 'step run count'
0,	i	step n's pause flag
8,	j	step n+1's setup number - next step number + 1
1,	k	step n+1's loop to step number
1,	l	step n+1's 'step run count'
0,	m	step n+1's pause flag
...	...	NOTE - steps can be added up to the maximum number of steps allowed, see B.9. Available Recipes Command:
CRC		CRC value in ASCII decimal
crLf		Carriage return and Line feed (0x0D 0x0A)

**Examples of Recipe Command:**

- Read recipe 1 from unit 1.  
@01r0#1,1,17069 (correct CRC value shown)
- Read recipe 7 from unit 1.  
@01r0#1,7,58030 (correct CRC value shown)
- ACK response to a read recipe command with default text delimiters.  
@01r1#33,1a,4b,1c,1d,0e,5f,1g,1h,0i,6j,1k,1l,0m,7n,1o,1p,0q,8r,1s,1t,0u,9v,1w,1x,0y,10z,1aa,1ab,0ac,4ad,1ae,1af,0ag,54321
- ACK response to a read recipe command with only 1 step and with text delimiters.  
@01r1#5,1a,4b,1c,1d,0e,54321
- Set command with comma delimiters, sets all units on the bus to same values.  
@00s1#33,1,4,1,1,0,5,1,1,0,6,1,1,0,7,1,1,0,8,1,1,0,9,1,1,0,10,1,1,0,4,1,1,0,54321
- Changing recipe 4, step 5 setup number to setup 3, on unit 1.  
@01s1#33,4,,,,,,,,,,,,,,,,,3,,,,,,,,,,,,,,,,,54321
- Activate recipe 8 on unit 1 (can also use the State command to activate recipes).  
@01s2#1,8,54321

**Notes:**

1. Reading recipe 0 reads the active values.
2. Reading recipe 1-10 reads the values saved in flash.
3. Setting recipe 0 changes active values only.
4. Setting recipe 1-10 saves the values to flash only.
5. Activate recipe 0 with no settings does nothing, with settings makes them active.
6. Activate recipe 1-10 saves the new settings, if any, to flash and loads the saved recipe into the active recipe.
7. Changing a setup in memory will change any recipe that uses that setup.
8. The State command can be used to activate recipes.
9. Recipes can be deleted using the User command.
10. Reading an erased or blank recipe will return a NAK response with the recipe number in the bad field value.
11. Setups that are used in a recipe must be loaded before attempting to run a recipe or a NAK will be returned.
12. This command is variable length depending on the number of recipes available in the unit. The number of steps in a command can vary from 1 to the maximum steps allowed.
13. The recipe can be named by adding a ':' (colon) after the recipe number and then the name of the recipe. There can be up to 19 characters in the name and can be any alphanumeric character including punctuation (except '@' and ','). More than 19 characters are ignored. For example this command will name recipe 2 on unit 01 as GoldFlashRcp\_02;  
@01r1#1,2:GoldFlashRcp\_02,54321

14. Use the set (or activate with step values) command for recipes sparingly because it writes to flash each time and flash has a limited lifetime of about 10,000 writes. Recipe number 0 only writes to RAM memory and basically has unlimited writes.

15. When using the Trickle option in a recipe the first step is the only one that needs to have trickle enabled as long as the recipe only stops at the end. If the recipe will be paused then all steps that might be paused will need the trickle settings set.



## B.19. Setup Command:

@01		Sync character and unit address, 00 = global, 01 to 99 is the unit address.
s1		Command character and Type - 0=read, 1=set, 2=activate, 3=ack, 4=nak
#34,		Number of fields character and number of fields after the comma, excluding CRC
1, or 1:Name,	a	setup number - 0=active, 1-10=saved setup name - optional, name the setup "TestSetup01" like this , 1:TestSetup01, See Note 16..
2,	b	regulation mode - 0=current, 1=crossover, 2=voltage See Note 15..
1.021,	c	forward current setting - amps, setting is peak pulse level.
8.5,	d	forward voltage setting - volts, setting is peak pulse level.
2.15,	e	reverse current setting - amps, setting is peak pulse level.
10,	f	reverse voltage setting - volts, setting is peak pulse level.
0,	g	current tolerance - % of setting, 0=disabled
0,	h	voltage tolerance - % of setting, 0=disabled
0,	i	fwd/rev timing resolution index For pulsed units, 0=xx.xx ms, 1=xxx.x ms, 2=x.xxx s, 3=xx.xx s. For CRSR or DCR 0=xxxx sec, xxxx min - See Note 13. below.
0,	j	on/off timing resolution index - 0=xx.xx ms, 1=xxx.x ms, 2=x.xxx s, 3=xx.xx s - See Note 13. below.
.003,	k	forward duration - mSec/Sec, limited by resolution digits of fwd/rev timing resolution index above. See Note 13. below.
.001,	l	forward on time - mSec/Sec, limited by resolution digits of on/off timing resolution index above. See Note 13. below.
.002,	m	forward off time - mSec/Sec, limited by resolution digits of on/off timing resolution index above. See Note 13. below.
.0005,	n	reverse duration - mSec/Sec, limited by resolution digits of fwd/rev timing resolution index above. See Note 13. below.
.0002,	o	reverse on time - mSec/Sec, limited by resolution digits of on/off timing resolution index above. See Note 13. below.
.0003,	p	reverse off time - mSec/Sec, limited by resolution digits of on/off timing resolution index above. See Note 13. below.
0,	q	RTC timing resolution index - 0=xxx.x sec, 1=xxxx sec, 2=xx.xx min, 3=xxx.x min, 4=xxxx min, 5=xx.xx hr, 6=xxx.x hr
0,	r	ATC amp-time resolution index - 0=x.xxx amp-min, 1=xx.xx amp-min, 2=xxx.x amp-min, 3=xxxx amp-min, 4=x.xxx amp-hr, 5=xx.xx amp-hr, 6=xxx.x amp-hr, 7=xxxx amp-hr.

1,	s	XTC mode - 0>manual, 1=ATC, 2=RTC (XTC means either ATC or RTC).
2.456,	t	XTC preset - Amin/Ahr or Sec/Min/Hr, limited by RTC/ATC resolution index above (XTC means either ATC or RTC).
0,	u	ATC accumulation mode - 0=forward, 1=forward-reverse (fwd minus rev)
0,	v	totalizer resolution index - 0=x.xxx amp-min, 1=xx.xx amp-min, 2=xxx.x amp-min, 3=xxxx amp-min, 4=x.xxx amp-hr, 5=xx.xx amp-hr, 6=xxx.x amp-hr, 7=xxxx amp-hr.
6.41,	w	relay amp-time preset - Amin/Ahr, in resolution units of totalizer resolution index above.
10,	x	relay on-time - minutes, xxx.x resolution.
0,	y	ramp time resolution index - 0=xxxx sec, 1=xxxx min
0,	z	ramp mode - 0=disable, 1=up, 2=down
15,	aa	ramp duration - Sec/Min, in resolution units of ramp time resolution index above.
10,	ab	ramp start offset - percent of signal setting (amps or volts, see note 8.), xx% resolution, 0=minimum, 99=maximum.
0,	ac	trickle flag - 0=disable, 1=enable
5,	ad	trickle level - percent of forward current setting, xx% resolution, 0=disable, 1=minimum, 99=maximum.
0,	ae	end-of-cycle alarm enable - 0=disable, 1=enable
0,	af	current error alarm enable - 0=disable, 1=enable
0,	ag	voltage error alarm enable - 0=disable, 1=enable
0,	ah	"relay on" alarm enable - 0=disable, 1=enable
CRC		CRC value in ASCII decimal
crlf		Carriage return and Line feed (0x0D 0x0A)

### Examples of Setup Command:

- Read setup command to read setup 1 on unit 1  
@01s0#1,1,33469 (correct CRC value shown)
- Read setup command to read setup 6 using global address with only 1 unit on the bus  
@00s0#1,6,32382 (correct CRC value shown)
- ACK response for a read setup command from unit 1 with text delimiters.  
@01s3#34,1a,2b,1.021c,8.5d,2.15e,10f,0g,0h,0i,0j,.003k,.001l,.002m,.0005n,.0002o,.0003p,0q,0r,1s,2.456t,0u,0v,6.41w,10x,0y,0z,15aa,10ab,0ac,5ad,0ae,0af,0ag,0ah,54321
- Basic set setup command with comma delimiters.  
@01s1#34,1,0,1.021,8.5,2.15,10,0,0,0,0,.003,.001,.002,.0005,.0002,.0003,0,0,1,2.456,0,0,6.41,10,0,0,15,10,0,5,0,0,0,0,54321

- Command changing only forward current in the active settings.

@01s1#34,0,,0.555,,,,,,,,,,,,,,,,,,,,,54321

- Command to activate setup 4 (can also use the State command to activate setups).

@01s2#34,4,,,,,,,,,,,,,,,,,,,,,,,,,,,,,54321

#### Notes:

1. Reading setup 0 reads the active values.
2. Reading setup 1-10 reads the values saved in flash.
3. Setting setup 0 changes active values only.
4. Setting setup 1-10 changes saved values to flash only.
5. Activate setup 0 with no settings does nothing, with settings changes the active values. The XTC value (ATC or RTC) when the unit is operate will change as follows. If the sent XTC value is the same it leaves the active XTC value unchanged, if a larger value is sent the duration left will increase by the difference and if the value is smaller the duration left will be reduced or set to 0 in which case the XTC cycle will end.
6. Activate setup 1-10 will save the new settings to flash and load the saved settings into the active settings. Note that this command will change the XTC value the same as described in 5 above.
7. Changing a setup in memory will change any recipe that uses that setup.
8. Current is ramped when either current or cross-over regulation is active. Voltage is ramped in voltage regulation mode.
9. The State command can be used to activate setups. Note that this command will change the XTC value (ATC or RTC) when the unit is in Operate. The active XTC value is reset to the value in the setup.
10. Setups can be deleted using the User command.
11. Reading an erased or blank setup will return a NAK response with the setup number field and value.
12. When changing resolutions the setting for that resolution should be part of the command so the setting is set to the proper number of decimal places.
13. Model Number notes (see also **B.21. Unit Command:**):
  - 13.1. DC and CRS units use no timing settings (can be 0 or blank).
  - 13.2. DCR and CRSR units use Fwd Dur and Rev Dur only (limited to Seconds or Minutes resolution).
  - 13.3. DP, DuP and CRSLFP units use only Fwd On time and Fwd Off time settings
  - 13.4. DPR, DuPR and CRSLFPR units use all timing settings
  - 13.5. DPD, DuPD and CRSLFPD units use all settings like 13.4 but reverse settings are used for a second output level.
  - 13.6. Units with LFP have a minimum On time of 4ms.
14. The timing resolution set will determine the smallest adjustable time increment which is the least significant digit of the resolution. Some of units have a minimum timing value depending on the model. The minimum time can be determined by using the Unit read command and checking the 'minimum pulse timing' field.

15. In Voltage Regulation mode the current is automatically adjusted to limit the average current of the output to the average current rating of the unit. The adjusted peak current setting for voltage regulation mode can be read back by reading the active settings using the Setup command. See section **6.1.7.3 SYS – System Key**, `2SetRegulationMode6`, `SYS`, `Set Reg Mode` for more information.
16. To name a Setup the delimiter in the 'setup number' field would have a ':' (colon) after the setup number and then text for the setup name. There can be up to 19 characters in the name and can be any alpha-numeric character including punctuation (except '@' and ','). More than 19 characters are ignored. For example this command will name setup 2 on unit 01 as `GoldFlashRamp_023;ab @01s1#34,2:GoldFlashRamp_023;ab,...`
17. Use the set (or activate with setup values) command for setups number 1 and above sparingly because it writes to flash each time and flash has a limited lifetime of about 10,000 writes. Setup number 0 only writes to RAM memory and basically has unlimited writes.
18. The timing resolution cannot be changed if the timing value in the setup is not compatible with that resolution. A NAK will be returned and all the settings in the setup command will be rejected.
19. If Host control is being used for Main-Secondary the settings to run the Secondary must be sent directly to the Secondary unit. Make sure the Timing is the same for both the Main and the Secondary in order to get the proper readbacks from the Secondary. See section **6.6.6 MSV - Master-Slave Control** for more information.

## B.20. State Command:

@00		Sync character and unit address, 00 = global, 01 to 99 is the unit address.
a0		Command character and Type - 0=read, 1=set, 2=activate, 3=ack, 4=nak
#4,		Number of fields character and number of fields after the comma, excluding CRC
1, a		operate state - 0=standby, 1=operate (max value for set), 2=pause (n/a for set), 3=inhibit (n/a for set), 4=trickle (n/a for set), 5=pause-trickle (n/a for set). (all values are valid for read). See Notes below.
1, b		setup number - 0-10, 0=unsaved values, 1-10=setups in flash.
2, c		recipe number - 0-8, 0=unsaved values, 1-8=recipes in flash, leave blank if recipe option not installed.
3, d		recipe step - 1-8
CRC		CRC value in ASCII decimal
crlf		Carriage return and Line feed (0x0D 0x0A)

### Examples of State Command:

- Read state of unit 01.

@01a0#0,50726 (correct CRC value shown)

- ACK response to a State read command with default delimiter text (unit in Opr, Setup 1, Recipe 2, Step 3).

@01a3#4,1a,1b,2c,3d,54321

- ACK response to a State read command with comma delimiters.

@01a3#4,1,1,2,3,54321

- Go to operate.

@01a1#4,1,,,,54321

- Activate recipe 3.

@01a2#4,,,3,,54321

### Notes:

1. This command can activate setups and recipes using either type 1, set, or 2, activate.
2. Activating a recipe (non-zero or non-blank recipe number field) overrides the setup field (i.e. if active settings has setup number 2 loaded and an activate command activates recipe number 1 with step 1's saved setup number 4, then setup 4 will become the active setup as part of recipe 1).
3. This command can activate a setup or recipe and go to operate in the same command. Note that this command will change the XTC value (ATC or RTC) when the unit is in Operate. The active XTC value is reset to the value in the setup.
4. Blank fields are ignored so whatever setting is currently active for that field will still be active after a command with a blank field (see Note 2. for exception).

5. The 'operate state' field can only have 0 (standby), or 1 (operate) for a set or activate command. All values listed can be returned for a read.
6. When the setup has an RTC or ATC, the first operate will put the unit into operate mode with active output unless as noted in Note 7. If a standby command is sent to the unit while it is running the RTC or ATC then the unit will go to the pause mode. If an operate command is sent when the unit is in the pause mode it will go back to operate and continue the cycle where it left off. If a standby command is sent while the unit is in the pause mode then the unit will go to standby.
7. When a setup has the optional trickle mode enabled, the first operate command will put the unit into trickle mode. The second operate command will put the unit into operate. Use read State commands to determine the unit's state. When in manual cycle control, the first standby will put the unit into trickle mode and the second standby will put the unit into standby. If the unit is running a timed cycle, ATC or RTC, then a standby sent while running the cycle will put the unit into pause-trickle mode, if an operate is sent the cycle will resume where it left off otherwise if a standby is sent the unit will go to trickle mode and if another standby is sent it will go to standby.
8. If a recipe is not active when a read command is sent, the setup field will have a value but the recipe and step fields will be blank in the response.

## B.21. Unit Command:

@00		Sync character and unit address, 00 = global, 01 to 99 is the unit address.
u0		Command character and Type - 0=read, 1=set(n/a), 2=activate(n/a), 3=ack, 4=nak
#32,		Number of fields character and number of fields after the comma, excluding CRC
101,	a	model type - 100=dp, 101=dpr, 102=dpd, 103=dup, 104=dupr, 105=dupd, 106=crs, 107=crsr, 108=crslfp, 109=crslfpr, 110=dc, 111=dcr, 112=crslfpd
0103456,	b	serial number - 01 is 2 digit year, 034 is day of year, 56 is day unit. Always 7 digits.
20,	c	fwd volt rating - volts
5,	d	fwd ave current rating - amps
10,	e	fwd pk current rating - amps
20,	f	rev volt rating - volts
5,	g	rev ave current rating - amps
10,	h	rev pk current rating - amps
1.,	i	firmware main version number - 0-255
12.,	j	firmware secondary version number - 0-255
45,	k	firmware proto version number - 0-255
0,	l	RMP, ramp option flag - 1=enabled
0,	m	RLY, relay option flag - 1=enabled
0,	n	ANA, analog option flag - 1=enabled
0,	o	RCP, recipe option flag - 1=enabled
0,	p	TKL, trickle option flag - 1=enabled
0,	q	MSV, main-secondary option flag - 1=enabled
0,	r	DRO, dual range output option flag - 1=enabled
1,	s	main-secondary number of units - 1=m-s disabled, 2-10=m-s enabled.
0,	t	main-secondary unit number - 0=main unit, 1-9=secondary unit
256.1,	u	unit on time - hours

21.2,	v	unit operate time – hours
256.1024,	w	unit amp-time total – Ahr (Fwd Ahr + Rev Ahr, rev adds positively)
51,	x	bulk calibration low – low cal value for units with adjustable bulk supply
300,	y	bulk calibration high – high cal value for units with adjustable bulk supply
5,	z	bulk headroom – headroom voltage level for units with adjustable bulk supply
10.0,	aa	dead time – dead time between forward and reverse timing, microseconds. 0=no dead time. 0.1us resolution.
0.1,	ab	minimum pulsing time – minimum pulsing time for direction or durations, milliseconds
1,	ac	terminal attached – 0=no terminal or not working, 1= terminal attached and working
105	ad	protocol version - 105 = version 1.05. Version of the protocol used in the version of firmware loaded. See the Protocol Revision History at the end of this section for changes made for each version.
2,	ae	forward range change current – the range will be in high when the current setting is equal to or above this value and in low when below this value.
2	af	reverse range change current – the range will be in high when the current setting is equal to or above this value and in low when below this value.
CRC		CRC value in ASCII decimal
crLf		Carriage return and Line feed (0x0D 0x0A)

### Examples of Unit Command:

- Read unit command.

@01u0#0,50454 (correct CRC value shown)

- ACK response to a read unit command with default text delimiters.

@01u3#30,11a,256024b,20c,5d,10e,20f,5g,10h,1i,12j,45k,1l,1m,0n,0o,1p,0q,0r,0s,0t,0u,0v,0w,0x,1y,0z,256aa,21.2ab,256.1024ac,106ad,54321

- ACK response to a read unit command with only comma delimiters.

@01u3#30,11,256024,20,5,10,20,5,10,1.,12.,45,1,1,0,0,1,0,0,0,0,0,0,0,0,1,0,256.1,21.2,256.1024,106,54321

### Notes:

1. This command is for reading the information only, setting is not allowed.
2. Values that do not apply to a unit can be blank or zero (i.e. DP units return reverse rating fields all zero or blank).
3. Serial number is a 7 digit number like 0123456 – 01 is 2 digit year, 234 is day of year



(ordinal date), 56 is day unit (next consecutive numbered unit serialized that day).

4. Model Number notes (see also **B.19. Setup Command:**):

4.1. DC and CRS units use no timing settings.

4.2. DCR and CRSR units use Fwd Dur and Rev Dur only (limited to Seconds or Minutes resolution).

4.3. DP, DuP and CRSLFP units use only Fwd On time and Fwd Off time settings

4.4. DPR, DuPR and CRSLFPR units use all timing settings

4.5. DPD, DuPD and CRSLFPD units use all settings like 4.4. but reverse settings are used for a second output level.

4.6. Units with LFP have a minimum On time of 4ms when pulsing but can put out DC also.

5. The Main-Secondary (M-S) fields (s & t) no longer determine what M-S mode the unit is in as of protocol version 1.09. Use the User Settings command to check and change M-S unit type.

## B.22. User Settings Command:

@00		Sync character and unit address, 00 = global, 01 to 99 is the unit address.
t1		Command character and Type - 0=read, 1=set, 2=activate, 3=ack, 4=nak. See Note 1.
#17,		Number of fields character and number of fields after the comma, excluding CRC
0,	a	external operate input option - blank=no action, 0=active while closed, 1=1 push, 2=2 push
0,	b	relay control options - blank=no action, 0=atc controlled, 1=on during operate, 2=on during alarm
0,	c	power-fail options - blank=no action, 0=go to standby, 1=go to trickle or pause, 2=20 second delay before going to operate after a power-fail if it was in operate at power-fail. See Note 10.
0,	d	edit protection flag - blank=no action, 0=editing allowed, 1=editing disabled (password required, see examples below), only active for panel control
0,	e	current password - blank=no action, 0 = default, 0 to 9999 allowed, (see examples below)
0,	f	new password - blank=no action, 0 = default, 0 to 9999 allowed, (current password required, see examples below). See Notes 3., 5. and 6.
01, or 01:Name,	g	unit address - 01 to 99, address of unit. Address 01 is the default when shipped unless a different value is requested by the customer. See Note 2.. unit name - optional, name the unit "GoldFlash01" like this , 01:GoldFlash01, See Note 18.
4,	h	baud rate - blank=no action, 0=9600, 1=19200, 2=38400, 3=57600, 4=115200 - 0 is default. The baud rate is persistent through power cycling. See Note 7., 8. and 9.
1,	i	delete setup - blank=no action, 0=set active settings to 0, 1 to 10 = setup number to delete from flash memory.
1,	j	delete recipe - blank=no action, 0=clear recipe mode and load blank setup, 1 to 8 = recipe number to delete from flash memory.
0,	k	set 'test/simulate mode' - blank=no action, 0=normal operation (test/sim mode disabled), 1= reference readback mode set, 2=simulator readback mode set. Password required to set test modes. CAUTION, the output of a normal power supply (not a simulator unit) is active in ref/sim modes. See Notes 11. and 12.
0,	l	set simulation mode load resistance - resistance = 0.000001 to 9999999 Ohms, 0=default resistance of (Voltage Rating / Peak Current Rating) for full range readings. blank=no action. See Notes 11. and 12.
0,	m	set control mode - blank = no action, 0=panel, 1=host, 2=analog, 3=panel-analog, 4=host-analog. See Notes 16. and 17.

0,	n	audible buzzer enable/disable – blank=no action, 0=disable, 1=enable (default). See Note 14. and 15.
0,	o	display mode - bit flags (not implemented yet)
0,	p	Main-secondary (M-S) unit type – 0=single stand alone unit, 1=main unit, 2=secondary unit. See Note 19. below.
0,	q	Dual-Range Mode flag – 0=auto range (default), 1=high range, 2=low range. Only works on units with the DRO (Dual Range Output) option.
CRC		CRC value in ASCII decimal
crlf		Carriage return and Line feed (0x0D 0x0A)

### Examples of User Settings Command:

- Read user settings command from unit 01,.  
@01t0#0,1631 (correct CRC value shown)
- ACK response to a read user settings command with text delimiters from Unit Address 01 and Baud Rate set to 115200.  
@01t3#17,0a,0b,0c,0d,e,f,01g,4h,i,j,0k,0l,1m,1n,1o,0p,0q,54321
- ACK response to a read user command with just comma delimiters.  
@01t3#17,0,0,0,0,,,01,4,,,0,0,1,1,1,0,0,54321
- Set edit protection, send edit protect flag and correct password.  
@01t1#17,,,,,1,0,,,,,,,,,,,,,54321
- Set password from 0 to 1234.  
@01t1#17,,,,,0,1234,,,,,,,,,,,,,54321
- Clear edit protection, send edit protect flag and correct password.  
@01t1#17,,,,,0,1234,,,,,,,,,,,,,54321
- Set unit address to 02. The unit must be the only one on the bus or all units will set the same address.  
@00t1#17,,,,,2,,,,,,,,,,,,,54321  
or @01c1#17,,,,,2,,,,,,,,,,,,,54321 if the unit address is known, see Note 2.
- Name unit 02 as GoldFlash02.  
@02t1#17,,,,,2:GoldFlash02,,,,,,,,,,,,,54321
- Same as above but using the variable length capability, see Note 20.  
@02t1#7,,,,,2:GoldFlash02,54321

### Notes:

1. Use the set command sparingly because it writes to flash each time and flash has a limited lifetime of about 10,000 writes. NOTE: As of protocol version 1.10 and M2h version 2.43.05 the "control mode, (m field)" is only saved to flash if the command type is "activate". The "set" type will only set the flag in RAM so that flash is not used up and will revert to the flash setting when power is cycled.

2. The unit address must be set by using the global address (00) on a single drop bus (only 1 unit on the 485 bus) if the unit address is not known. If the address of the unit is known, then the unit can be addressed and the address changed using the set command (make sure no other unit on the 485 bus has the same address). The unit address and baud rate can also be set using the control panel if one is attached.
3. The password fields are always blank for a read.
4. When Edit Protect is enabled (=1) settings cannot be changed via the panel but can be changed via the host.
5. The correct password must be sent in order to set a new password or change the edit protect flag or set the test RB mode.
6. When the password is being set, password protected settings (i.e. edit protect) can be changed with the same command (correct old password is required).
7. The default baud rate is 9600. If the baud rate is unknown it can be found by setting the baud rate on a terminal program to 115200 and checking the data dumped out the USB port at power-up (using the USB Virtual Com Port driver), see **Section B.5**. It can also be found and/or set using the optional user interface control panel menus.
8. When setting the baud rate the ACK response is returned at the same baud rate as when the command is received. The baud rate change occurs after the ACK is sent.
9. The baud rate and unit address are retained after the power is cycled.
10. Power-fail options: If go-to-standby then the unit will always go to standby after a power-failure and power is restored. If go-to-trickle-or-pause then if the unit was in operate at power-failure it will go to trickle-pause if trickle was enabled or to pause if not when power is restored. If go-to-operate then if the unit was in operate it will return to operate after 20 second delay after the power is restored.
11. Readings returned during Test/Sim 'Reference Readback Mode' are not calibrated. This mode is just for testing the D/A and A/D converters. The simulation mode will give readbacks according to the levels set and the Simulation Resistance set.
12. Test/Sim modes go away after power is cycled.
13. CAUTION: The output of a normal power supply (not a simulator unit) is active during the Test/Sim modes.
14. The audible buzzer enable/disable is not persistent through power cycling, it defaults to enabled.
15. The alarms will always set the flag in the Alarm command if that alarm is enabled using the Setup command but will only sound the audible buzzer if the audible buzzer field in the User command is enabled.
16. The unit must be in Host Control mode for the setup-set, recipe-set and state-set commands to work. If not in host control the command will return a NAK. Reading commands work in any mode.
17. The Control Mode setting is saved through power cycling (when host mode is set, note that the panel mode is active after power is cycled until the first host command is received).
18. The unit can be named by adding a ':' (colon) after the unit address and then the name of the unit. There can be up to 19 characters in the name and can be any alpha-numeric character including punctuation (except '@' and ',')(more than 19 characters are ignored). For example this command will name unit 01 as GoldFlash\_02;  
@01t1#1,2:GoldFlash\_02,54321
19. As of protocol version 1.09 and Mach2host code version 2.40.14 the main-secondary

unit type can be set using the "p" field in this command. Using main-secondary mode, 2 or more units can be connected together (with the optional M-S board and cables) and the main unit controls the operation of the secondary unit(s). The "single" mode is used when the units are running different processes by themselves. The "main" mode is used for the unit that controls 1 or more secondary units. The "secondary" mode is set on units that are controlled by the main unit.

20. As of protocol version 1.10 and M2h version 2.43.05 the User command is variable length. Any missing fields at the end of a "set" command will be ignored.

## B.23. Protocol Revision History:

Rev	Description	Date
1.00 Mach2 Code Compatibility V2.00.00	Initial Release	09/30/2008
1.02 Mach2 Code Compatibility V2.02.00	The Unit command now reports Amp-Time in Amp-Hours, was Amp-Minutes.	11/05/2008
1.03 Mach2 Code Compatibility V2.03.00	Added more RTC resolutions, xxxx Sec, xxxx Min and xxxx Hr. The selection order in the Setup command, RTC Resolution field changes: from 0=xxx.x sec, 1=xx.xx min, 2=xxx.x min, 3=xx.xx hr, 4=xxx.x hr to 0=xxx.x sec, 1=xxxx sec, 2=xxx.x min, 3=xxx.x min, 4=xxxx min, 5=xx.xx hr, 6=xxx.x hr, 7=xxxx hr	12/18/2008
1.04 Mach2 Code Compatibility V2.04.00	1. Added ability to have a setup and/or recipe name, see their respective commands. 2. The alarm set command can now clear an EOC alarm.	03/02/2009
1.05 Mach2 Code Compatibility V2.05.06	1. The protocol revision number is now in the Unit command. 2. Added the ability to have a Unit Name, see the User command. 3. Changed the Recipe command to variable length. The length will change depending on the number of recipe steps for both the Read and Set/Activate command types, see the Recipe command. 4. Added a 'Number of Steps available' field to the Available Recipes command. This field is the first field so that the command can be variable length depending on the number of recipes allowed. 5. Added a field to the Alarm command for CRC error. A CRC error used to return a NAK with a CRC flag but does not any more. 6. Added 2 fields to the User command. The first will be a Display Options value to change how the display works under certain circumstances. The second is a spare field. 7. Added a new value to the Settings Error field in the NAK command, 5=invalid timing. 8. Added a new state to the Operate State field in the State command, 5=pause-trickle.	03/27/2009

	<p>9. The readings command is now variable length. The basic command is the same but if a recipe is active there is an extra field for each step in the recipe. The field contains the 'number of times to run the step' value for looping.</p> <p>10. The fwd and reverse totalizers can now be reset to 0 or preset to a desired value. Only in V2.06.02 or later.</p>	
1.06 Mach2 Code Compatibility V2.09.06	<p>1. Changed the responses to sending values for Option Not Installed, see the NAK command.</p> <p>2. Added more NAK responses for Flash Write Errors when saving a Setup or Recipe, see the NAK command.</p> <p>3. Added more NAK responses to the Cannot Operate field, see the NAK command.</p> <p>4. Added the Forward/Reverse Timing Resolutions for the CRSR and DCR models to the description in the Setup command.</p>	05/28/2009
2.10.03	Added Protocol Version to the Unit command, now 30 fields.	07/06/2009
1.07 Mach2 Code Compatibility V2.11.03	The CRC and Unknown Command errors were moved from separate Alarm command fields and added to the Comm Error Bit Flags field. Flags for Data Overrun, Noise Error, Framing Error, and Parity Error were also added to this field. See the Alarm command.	08/28/2009
1.08 Mach2 Code Compatibility V2.12.03	Added the forward and reverse Dual Range change current level fields to the Unit command, now has 32 fields.	10/06/2009
V2.14.16	Command Overrun error bit was not being output with the Alarm and NAK commands.	12/07/2009
V2.16.01	<p>Alarm command with global address (00) will clear all alarms in all units on a RS485 bus.</p> <p>Setup values are accepted in operate now.</p> <p>Fixed the Unit command Peak and Average current ratings values for dual range units.</p>	01/11/2010
V2.18.01	Unit returns normal setup values rather than the trickle values when in trickle mode and the Setup read command is used.	03/04/2010
1.09 V2.40.14	<p>Added Error History (h) command.</p> <p>Added M-S Unit Type to the User Settings command using the spare "p" field so has the same number of fields.</p>	09/04/2012
1.10 v2.43.05	1. Added the Dual-Range Mode flag to the User Settings command. The User command is now variable length. The "read" type will always return a 17 field command now.	01/07/2013

	2. Made a slight change to Note 4 under the Calibrate Output command. Removed the reference to a calibrator.	
--	--	--



## C. Pulse Mathematics

This section describes how to calculate various setting for Pulse and Pulse Reverse plating.

### C.1. Pulse Plating Calculations

The following sections give the details for calculating the plating parameters when using pulsed power supplies.

#### C.1.1. Overview - DC versus Pulse

This Section discusses how to determine Duty Cycle, Average Current, Peak Current, Average Voltage, Peak Voltage, and Plating Cycle Preset.

Platers are accustomed to calculating plating time (ampere-time) using D.C. amperage which, for practical purposes, is a steady, unchanging current. See **Figure 9.1a**. When a pulse power supply is used, the current is no longer steady and unchanging. It now is ON for some time and OFF for some time. This is depicted in **Figure 9.1b**.

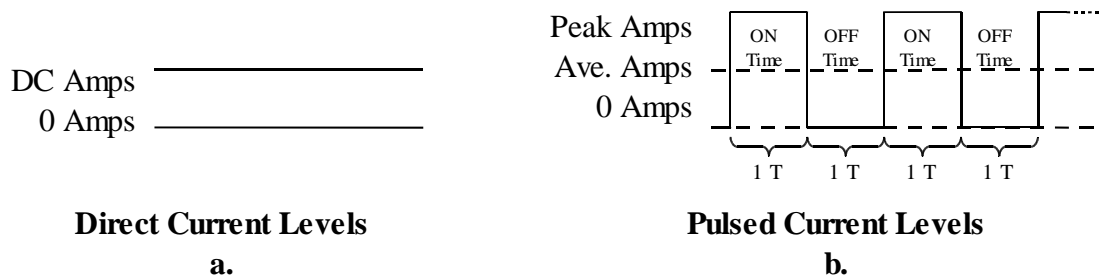

**Figure 9.1: DC versus Pulse Currents**

This ON and OFF current introduces the parameter DUTY CYCLE into the calculations. This is the ratio that the power supply is ON in relation to the total ON and OFF (cycle) time.

As shown in **Figure 9.1**, the level of current during the ON time of the Pulsed Current is twice the amplitude of the D.C. Current. However, the current is only there half of the time since both the ON and OFF times are 1 Time unit long. Therefore, twice the amplitude times half of the time will equal one ( $1/2 \times 2 = 1$ ) or if the upper half of the pulse ON Time in Figure 7-1b were placed in the lower half of the OFF time the energy in the output would equal one times the D.C. level shown in **Figure 9.1a**.

The amplitude of the pulse (ON time) is called PEAK current. The level of energy which is equal to the D.C. level when time (or DUTY CYCLE) is considered is called AVERAGE current.

The relationship of these 3 parameters is:

$$Average\_Current = Peak\_Current \times Duty\_Cycle$$

Basically, all pulse plating calculations are performed to obtain the D.C. equivalent (AVERAGE) current to allow the plater to control the plating thickness. Pulse mathematics

are straight-forward when calculating unipolar (single direction ON and OFF) parameters. Unipolar may be either cathodic or anodic. As the pulse waveform becomes more complicated, so do the calculations. This will be apparent when PERIODIC REVERSE is introduced. Also remember that the same relationship ( $Avg. = Pk. \times Duty\ Cycle$ ) given above for current is true when calculating voltage.

---

### C.1.2. Duty Cycle for Pulse

---

As previously stated, DUTY CYCLE is the ratio of the ON time to the total ON and OFF period (cycle) time. Referring to **Figure 9.2**, the total ON and OFF period time is 10 milliseconds (ms). The ON time is 1ms. and the OFF time is 9ms. This is a 10% DUTY CYCLE because the ON time is 1/10 of the period (ON + OFF).

$$Duty\_Cycle\ (DC) = \frac{ON\_Time}{ON\_Time + OFF\_Time}$$

$$DC\ \% = \frac{1ms}{1ms + 9ms} \times 100 = \frac{1ms}{10ms} \times 100 = 0.1 \times 100 = 10\%$$

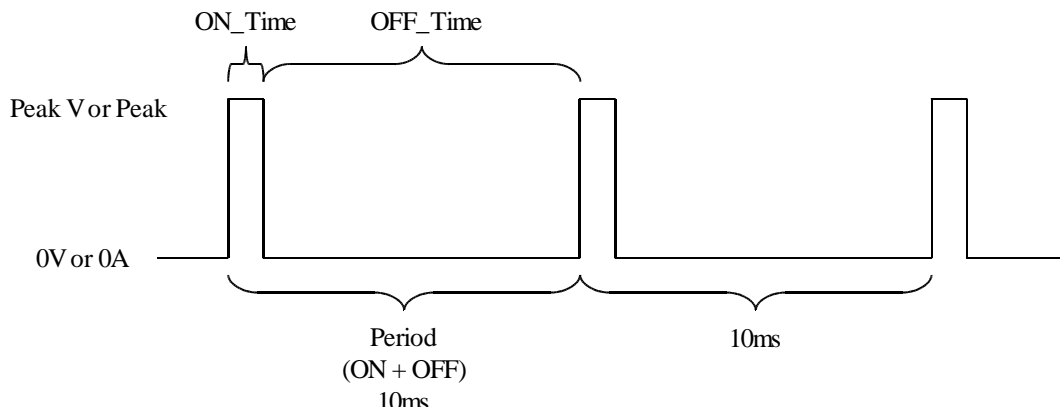

**Figure 9.2: Duty Cycle**

If the ON time increases and the OFF time decreases by the same amount, the ON + OFF period time would remain the same while the DUTY CYCLE would increase. For example, if the ON time was 2ms and the OFF time 8ms the ON + OFF period would be the same, 10ms, but the DUTY CYCLE would become 20%.

The fact that the PERIOD did not change means that the FREQUENCY of the pulsed waveform is not changing either since:

$$Frequency = \frac{1}{Period}$$

Therefore, DUTY CYCLE can be changed while maintaining a certain FREQUENCY by changing ON and OFF time equal but opposite amounts.

Conversely, FREQUENCY can be changed while DUTY CYCLE remains unchanged by changing both ON and OFF times by proportionate amounts in the same direction. For example, if, in the previous example where ON time was increased to 2 mS, the OFF time was increased two-fold also instead of decreased by 1 mS, the DUTY CYCLE would be:

$$DC (\%) = \frac{2ms}{2ms + 18ms} \times 100 = \frac{2ms}{20ms} \times 100 = 0.2 \times 100 = 20\%$$

The FREQUENCY, however, would be:

$$Frequency = \frac{1}{2ms + 18ms} = \frac{1}{20ms} = 50Hz$$

Whereas, in the first example, it was:

$$Frequency = \frac{1}{1ms + 9ms} = \frac{1}{10ms} = 100Hz$$

---



---

### C.1.3. Peak Regulation

---



---

Dynatronix power supplies are PEAK regulated whether they are constant current or constant voltage. This means that the operator control sets the PEAK current or voltage and the power supply holds that peak value constant (during ON\_Time) despite any change in load resistance or DUTY CYCLE.

A change in DUTY CYCLE, with the PEAK being held constant, will change the AVERAGE output in accordance with:

$$Average\_Current = Peak\_Current \times Duty\_Cycle$$

---



---

### C.1.4. Average Readbacks

---



---

All Dynatronix Power Supplies, whether manual, programmable or both, measure, display and/or report output in AVERAGE. This is appropriate as AVERAGE is the equivalent of D.C. with which the majority of plating personnel are familiar. AVERAGE, which is the product of PEAK and DUTY CYCLE, is, therefore, used in calculating current density and AMPERE-TIME among other things.

---

### C.1.5. Ampere-Time for Pulse Plating

---

AMPERE-TIME is used to control plating thickness and is calculated as follows:

$$\text{Ampere-Time} = \text{Average\_Current} \times \text{Time}$$

If an Ampere-Time Controller is being used to determine the plating cycle (thickness), the AMPERE-TIME is set directly into the PRESET. The ATC then monitors the output current over a period of time, calculates the AMPERE-TIME and stops the plating when the PRESET amount is reached.

---

### C.1.6. Real Time Control for Pulse Plating

---

If a Real-Time Timer is used instead, it is PRESET to the TIME which the power supply must run at a given AVERAGE current to reach the correct AMPERE-TIME. The TIME is calculated as follows:

$$\text{Time (to be Preset)} = \frac{\text{Required Ampere-Time}}{\text{Average\_Current}}$$

---

## C.2. Periodic Reverse (PR) Plating Calculations

---

Periodic Reversing or Bipolar Power Supplies have the capability of changing the direction or polarization of the output. The output in the same direction as a unipolar unit is called FORWARD. This is when the (+) terminal (anode) is positive with respect to the (-) terminal (cathode). Output in the opposite direction as a unipolar unit is called REVERSE. This is when the (+) terminal (anode) is negative with respect to the (-) terminal (cathode).

---

### C.2.1. Duty Cycle for PR

---

Calculating the DUTY CYCLE for P/R is essentially the same as for unipolar - the ratio of the ON time to the total PERIOD or cycle.

As seen in **Figure 9.2**, the PERIOD is the total ON + OFF time or the PERIOD of time from a beginning point of the waveform to the point where the waveform begins to repeat. This is one cycle or PERIOD.

With PERIODIC REVERSE, there are 3 possible PERIODS:

- 1) Forward ON + OFF
- 2) Reverse ON + OFF
- 3) FORWARD + REVERSE

**Figure 9.3** points out these different PERIODS using a P/R waveform with pulsing in both directions.

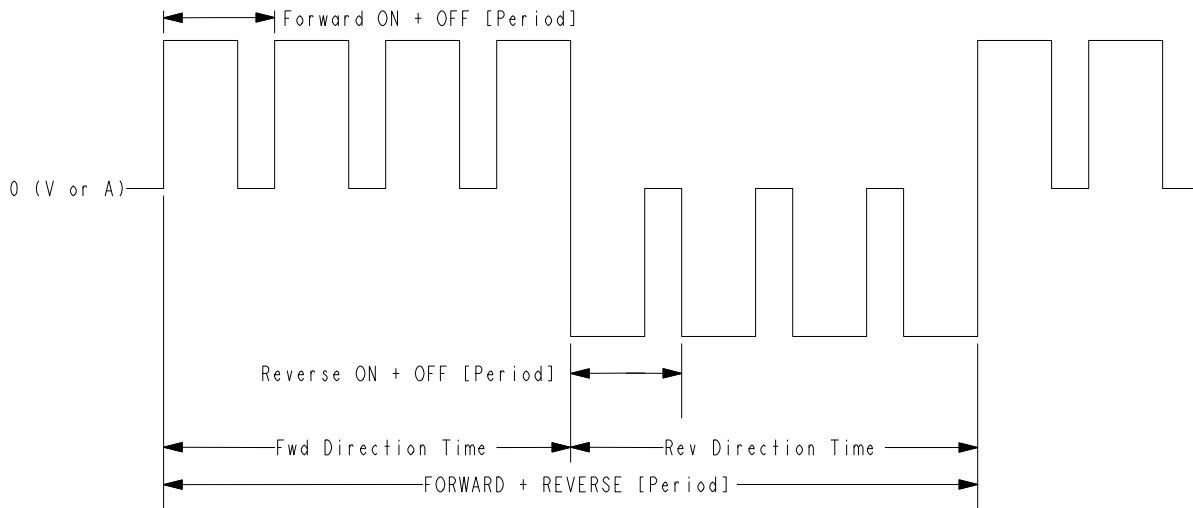

**Figure 9.3: Three Possible Periods of a Waveform**

The difference in calculating DUTY CYCLE of unipolar and bipolar waveforms is that with unipolar it is only necessary to deal with one PERIOD - the ON + OFF. Only one ON time and one PERIOD (ON + OFF) is used. Whereas, with bipolar, several ON + OFF PERIODS, as well as the FWD + REV PERIOD must be used to determine DUTY CYCLE. P/R DUTY CYCLE is sometimes referred to as the EFFECTIVE DUTY CYCLE and is calculated as follows for a given direction:

$$Eff\_DC (this\ direction) = \frac{Total\ ON\ Time\ (this\ dir.)}{Time\ (this\ dir.) + Time\ (opposite\ dir.)}$$

The two most important things to remember are that any time in the opposite direction is the same as OFF time to the direction being calculated and that all of the ON time must be considered for the direction being calculated not just the ON time of one ON + OFF period.

The difficult part of the calculation is the TOTAL ON TIME, especially if there is not an even number of ON + OFF cycles in the direction being calculated.

To determine the TOTAL ON TIME (this direction), the number of ON + OFF cycles must be extracted.

This is accomplished by dividing the time for the 'direction being calculated' by the ON + OFF period (this direction). Take the integer (whole number) from this calculation and multiply it by the ON time setting (this direction). Note this value as it is to be used later.

Next any fractional value remaining from the number of ON + OFF cycles calculation is multiplied times the ON + OFF period time (this direction). If the ON time setting (this direction) is larger than this value, add this value to the noted value above. This is the TOTAL ON TIME (this direction). If the value is larger than the ON time setting (this direction), add the ON time setting to the previously noted value and this is the TOTAL ON TIME (this direction).

For example if the Forward and Reverse timing for **Figure 9.3** was 2ms ON, 1ms OFF, and 10ms Direction Time, then the Total ON time is calculated with:

$$\text{Full Cycles} = \frac{\text{Direction Time}}{\text{ON\_Time} + \text{OFF\_Time}} = \frac{10\text{ms}}{2\text{ms} + 1\text{ms}} = 3.3333 \text{ cycles} = 3 \text{ full cycles}$$

$$\text{Full Cycles ON Time} = \text{Full Cycles} \times \text{ON\_Time} = 3 \text{ cycles} \times 2\text{ms} = 6\text{ms}$$

$$\text{Partial Cycle Time} = \text{Remainder} \times (\text{ON} + \text{OFF times}) = 0.3333 \times (2\text{ms} + 1\text{ms}) = 1\text{ms}$$

*Partial Cycle ON Time: Since 1ms is less than the ON\_Time, 1ms is the partial cycle ON time*

$$\text{Total ON time} = \text{Full Cycle ON time} + \text{Partial Cycle ON Time} = 6\text{ms} + 1\text{ms} = 7\text{ms}$$

Once the TOTAL ON TIME is known, simply divide it by the sum of the TIME (this direction) + TIME (opposite direction), which is the FWD + REV PERIOD, to obtain the EFFECTIVE DUTY CYCLE (this direction). Multiply by 100 to put into a percentage if desired. As with unipolar, once the EFFECTIVE DUTY CYCLE is determined, it is multiplied by the PEAK current set for this direction to obtain the EFFECTIVE AVERAGE current (this direction). These calculations are shown below:

$$\text{Eff Duty Cycle (this dir)} = \frac{\text{Total ON Time (this dir)}}{\text{Time (this dir)} + \text{Time (opp dir)}} = \frac{7\text{ms}}{10\text{ms} + 10\text{ms}} = 0.35 \text{ or } 35\%$$

$$\text{Effective Average Current (this dir)} = \text{Eff Duty Cycle (this dir)} \times \text{Peak Current (this dir)}$$

If the peak current was set to 10Amps then the effective average current would be:

$$\text{Effective Average Current (this dir)} = 0.35 \times 10\text{Amps}$$

$$\text{Effective Average Current (this dir)} = 3.5\text{Amps}$$

The next step is to calculate AMPERE-TIME PRESET to ultimately determine the plating thickness.

---

### C.2.2. Ampere-Time Preset for PR

---

When using a unipolar power supply, the AMPERE-TIME Preset for the ATC is simply set to the AMPERE-TIME required to get the desired plated thickness. Or, if a Real-Time Timer is being used, the TIME needed to get the desired plating thickness.

However, in order to obtain the desired plated thickness when using a PR power supply, the REVERSE AMPERE-TIME must be factored in because any time spent in REV subtracts from the progress made during FWD due to the fact that REV actually etches material away (mostly at the desired locations where over-plating occurs).

The MicroStar Reversing power supplies have settings for the ATC Accumulation method. It can be left as Forward Only or set to Forward-Reverse. When this setting is set to Fwd-Rev it will take the reverse current into account. When this setting is enabled the Required AMPERE-TIME can be entered directly into the ATC Preset. The Accumulation method can be set using the **6.1.7.2 CYCLE CNTL – Cycle Control Key**, 10 SubtractReverseAmpTime menu item.

$$Eff\_Plate\_Current = Eff\_Fwd\_Current - Eff\_Rev\_Current$$

AMPERE-TIME Controllers that only accumulate the FWD AMPERE-TIME, do not take into account the reverse deplating current. Therefore a larger number will have to be entered into the PRESET so that the actual plating cycle would plate for the time required by the EFFECTIVE PLATE CURRENT which is calculated by:

The PERIODIC REVERSE AMPERE-TIME Preset for FWD Only ATC accumulation is determined as follows:

$$ATC\_Preset\_Fwd\_Only = Eff\_Fwd\_Current \times \frac{Required\_Ampere-Time}{Effective\_Plate\_Current}$$

---

### C.2.3. Real-Time Preset for PR

---

If a Real-Time timer is being used to control the plating cycle then that time must be calculated. Having calculated the EFFECTIVE PLATING CURRENT above, the actual plating time required can be determined by dividing the AMPERE-TIME required for the desired thickness by the EFFECTIVE PLATING CURRENT:

$$Plating\_Time = \frac{Required\_Ampere-Time}{Effective\_Plate\_Current}$$

This TIME would be entered into the Real Time Cycle (RTC) PRESET.

NOTE: If AMPERE-TIME is recorded for chemical additions, some chemicals may be depleted in REV. as well as FWD. in which case the FWD. AVERAGE CURRENT and REV. AVERAGE CURRENT should be added rather than subtracted for that particular situation of adding chemicals to the plating bath.

---

### C.2.4. Reverse Deplating Ratio

---

One more parameter that may be considered is the REV DEPLATING RATE of the bath being used. Certain baths may deplate (etch) slower (or faster) than they plate and would thus affect the AMPERE-TIME PRESET required for the desired plating thickness. If the REV DEPLATING RATE is the same as the FWD PLATING RATE then the REV DEPLATING RATE factor would be 1.00. If it deplates 10% slower than the plating rate it would be a factor of 0.90. The calculation for EFFECTIVE PLATING CURRENT that includes the Rev Deplating Ratio is:

$$Eff\_Plate\_Current = Eff\_Fwd\_Current - (Eff\_Rev\_Current \times Rev\_Deplate\_Rate)$$

---

### C.2.5. Dead Time for PR

---

Dead Time is a factory determined setting. It is an off time between direction changes in Dynatronix pulse reversing power supplies. **Figure 9.4** shows Dead Time locations. Dead Time is actually a time between direction changes where the output is 0 Amps. Dead Time is repeatable, and is almost always of extremely short duration. Due to these factors, it can be, and is, generally disregarded in duty cycle calculations.

The Dead Time on a MicroStar Reversing power supply is typically 10 microseconds.

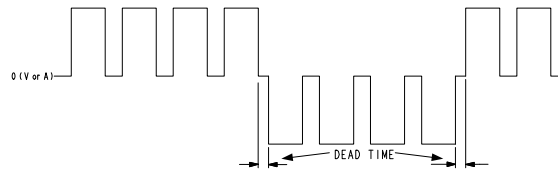

**Figure 9.4: Dead Time Location for PR Waves**



